

Wiringkit

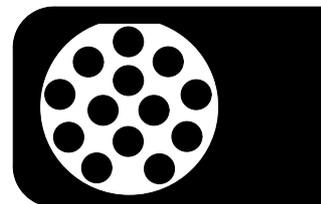

- D** Einbauanleitung
- GB** Installation instructions
- F** Consignes de montage
- NL** Montagehandleiding
- DK** Montagevejledning
- N** Monteringsinstruksjon
- S** Installationsanvisning
- FIN** Asennusohje
- I** Istruzioni per il montaggio
- E** Instrucciones de montaje
- P** Instruções de montagem
- GR** Οδηγίες εγκατάστασης
- CZ** Návod k montáži
- SLO** Navodilo za vgradnjo
- SK** Montážny návod
- PL** Instrukcja montażu
- TR** Montaj talimatı
- H** Beépítési útmutató
- HR** Upute o ugradnji
- BUL** Инструкция за монтаж
- RO** Instrucțiuni de montaj
- RU** Инструкция по монтажу и установке
- LT** Montavimo informacija
- LV** Iemontēšanas pamācība
- EST** Paigaldusjuhend

701504

SEAT

- **Leon 5F SC/5 Door** 02/13 >> 03/20
- **Leon 5F ST / X-perience** 11/13 >> 05/20

PR: 1D0 / 1D8 / 1M5

LHD + RHD

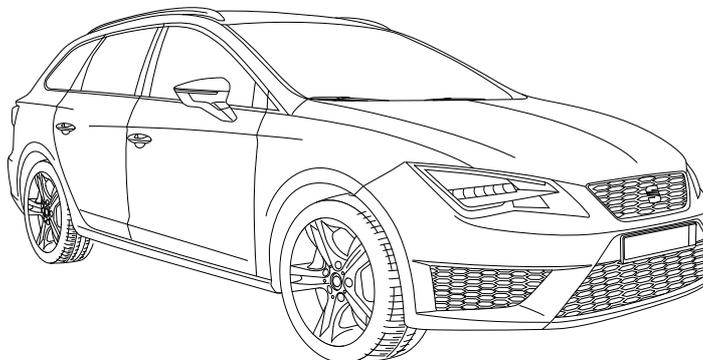
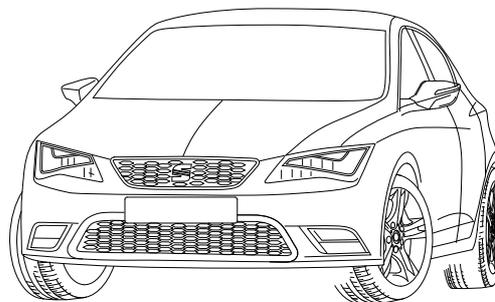
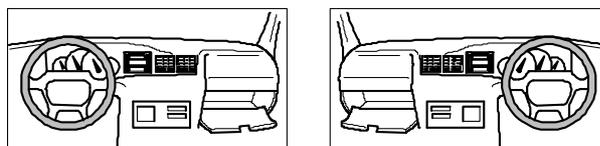

INFORMATION

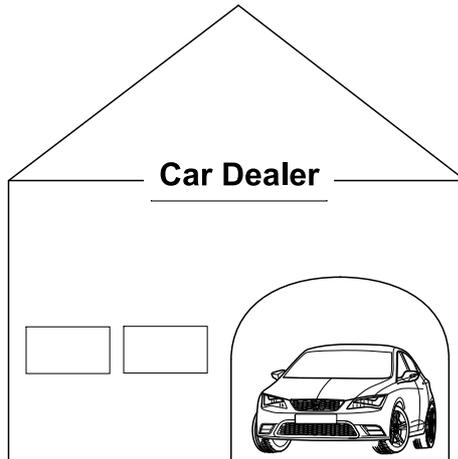

oder / or

Serviceplan

1. VSSZZZ 5F Z

2. 5F1 5TY
LEON 2.0 CR
FR 5T135 DK7AU6

3. CUNA

LY9T CP

4.

X0A	B0A	DK7	G1A	1AT	8GU
J2D	C0T	H7D	—	1G9	1NL
I8H	8ZH	9VD	8IT	8WH	8TB
Q4H	4A3	2PK			
1D0	2B2	—	5SJ	5RQ	QG1
7MM	G03				

5. 5.5 4.0 4.5
— — 119

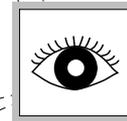
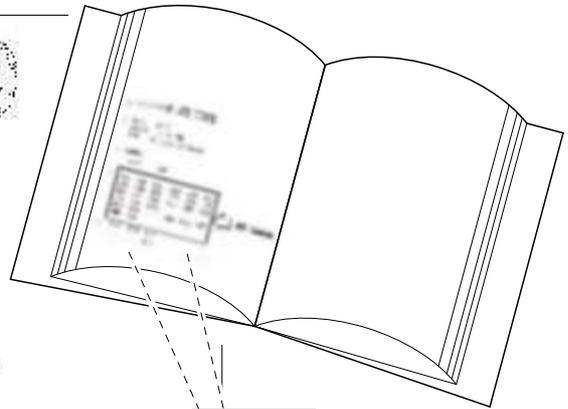

PR: Codes

OVERVIEW

For vehicles with trailer preparation PR: 1D8 / 1M5

PR: 1D8
>> 05/14

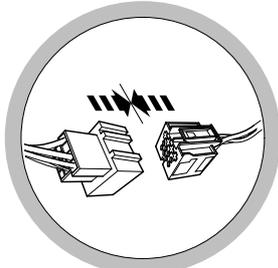

I

PR: 1M5



PR: 1D8
06/14 >>

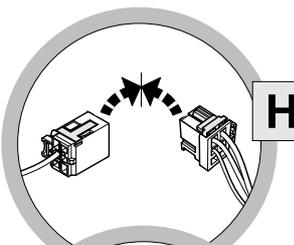

H

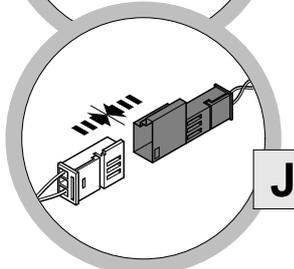

J

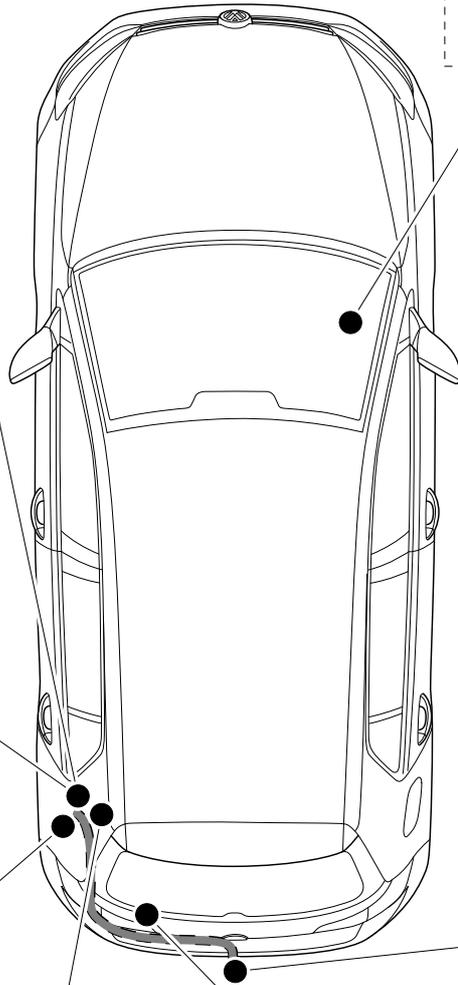

A B C

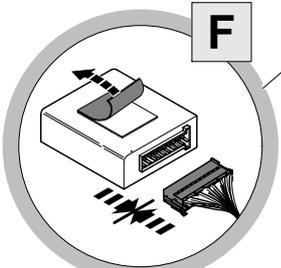
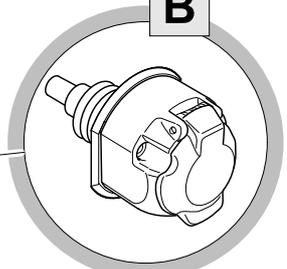

F

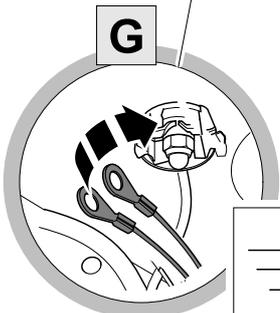

G

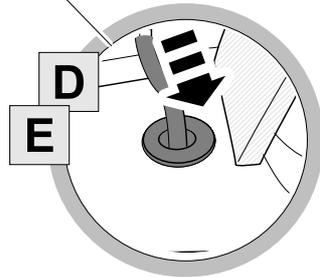

D E

OVERVIEW

For vehicles without trailer preparation PR: 1D0

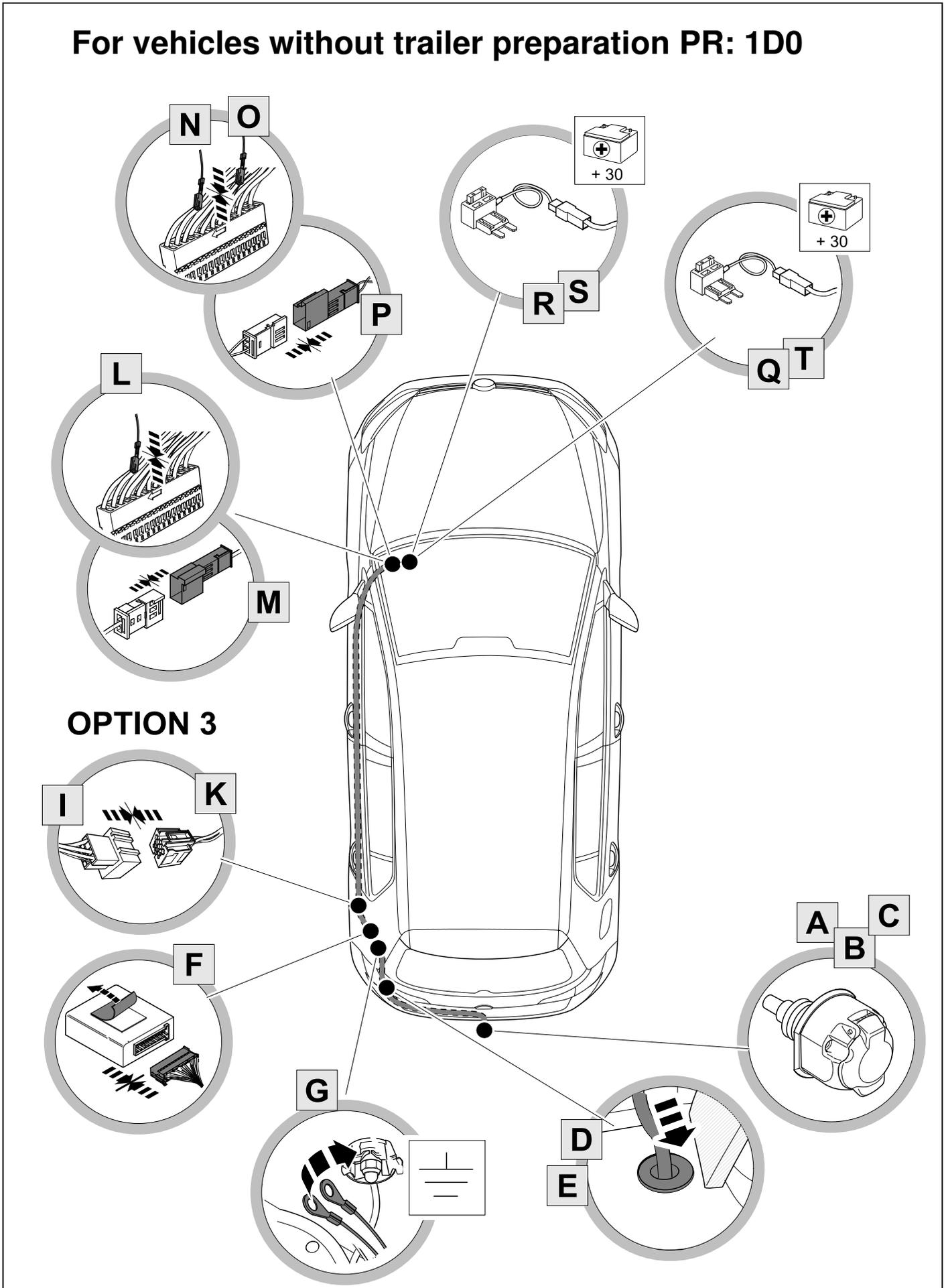

KIT

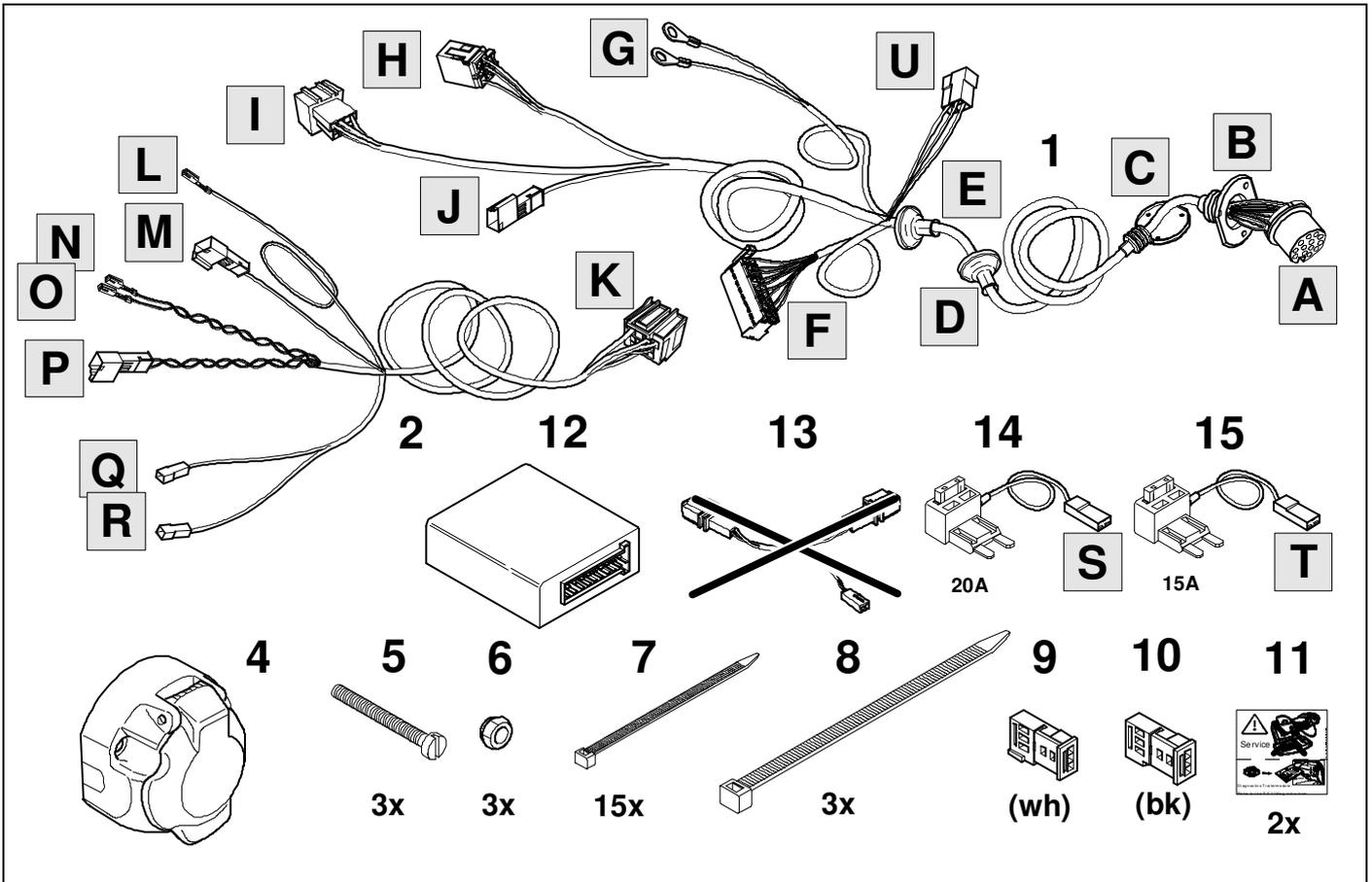

TOOLS

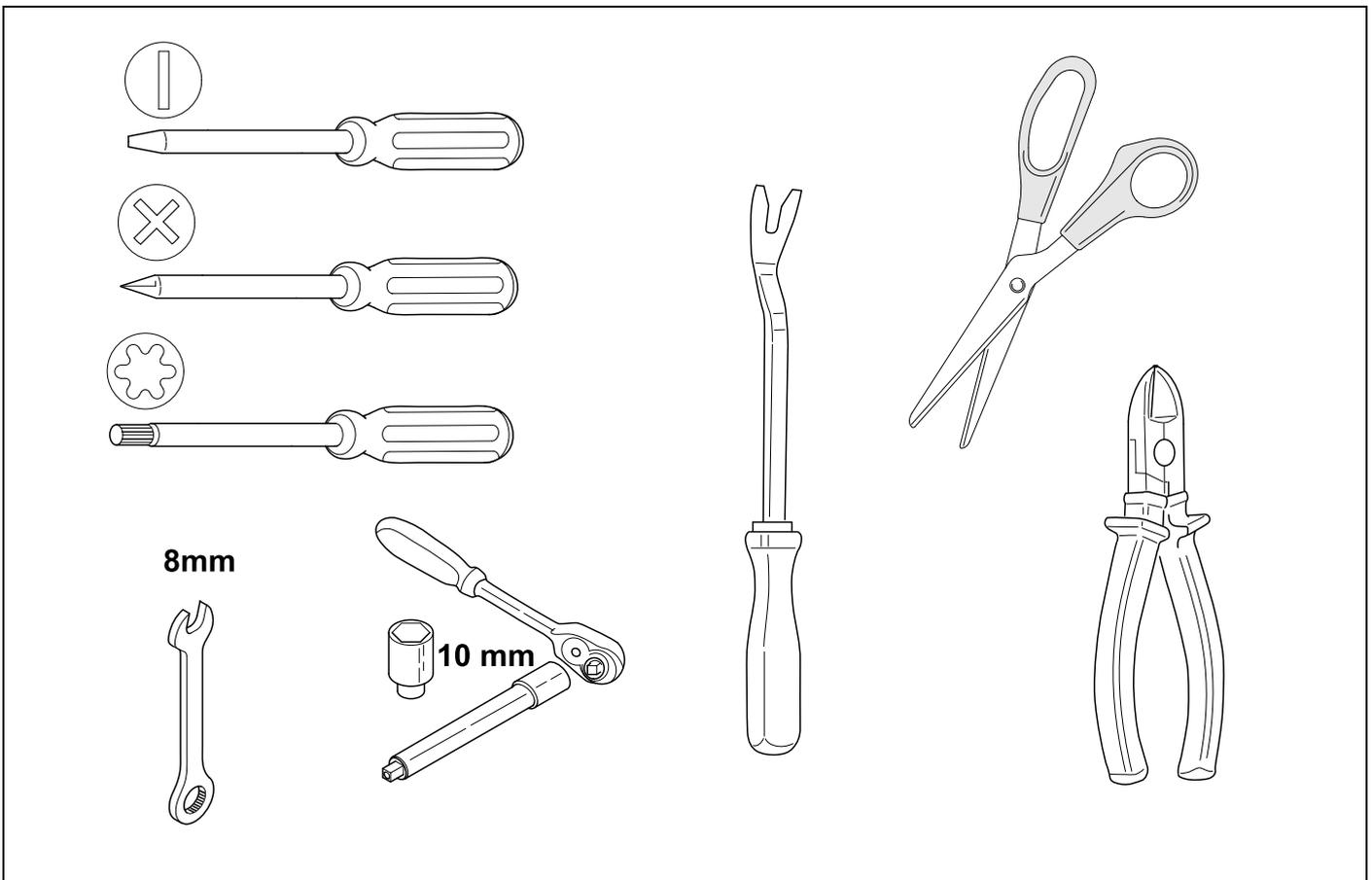

1

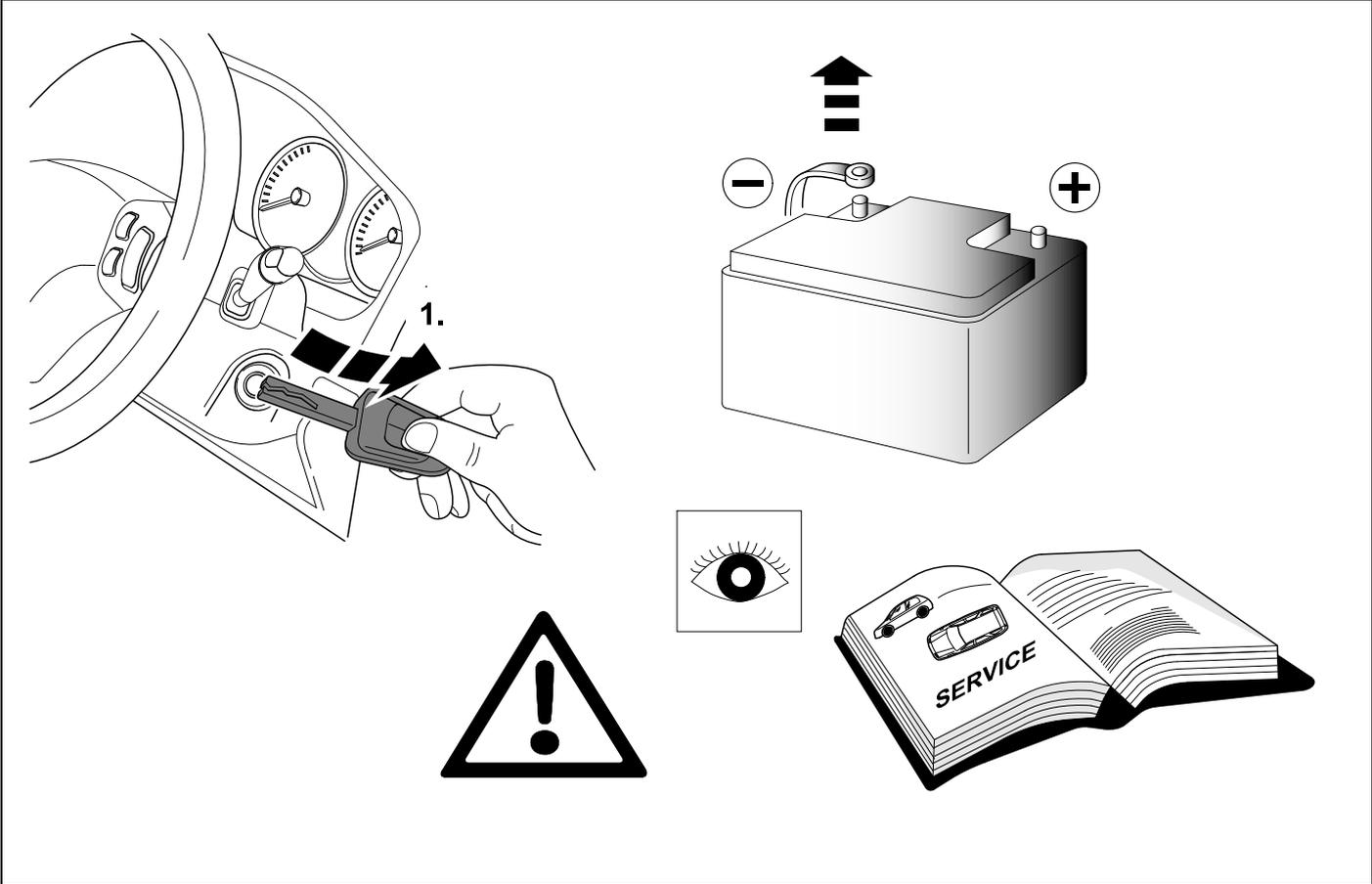

2 REMOVE

Leon PR: 1D8 / 1M5

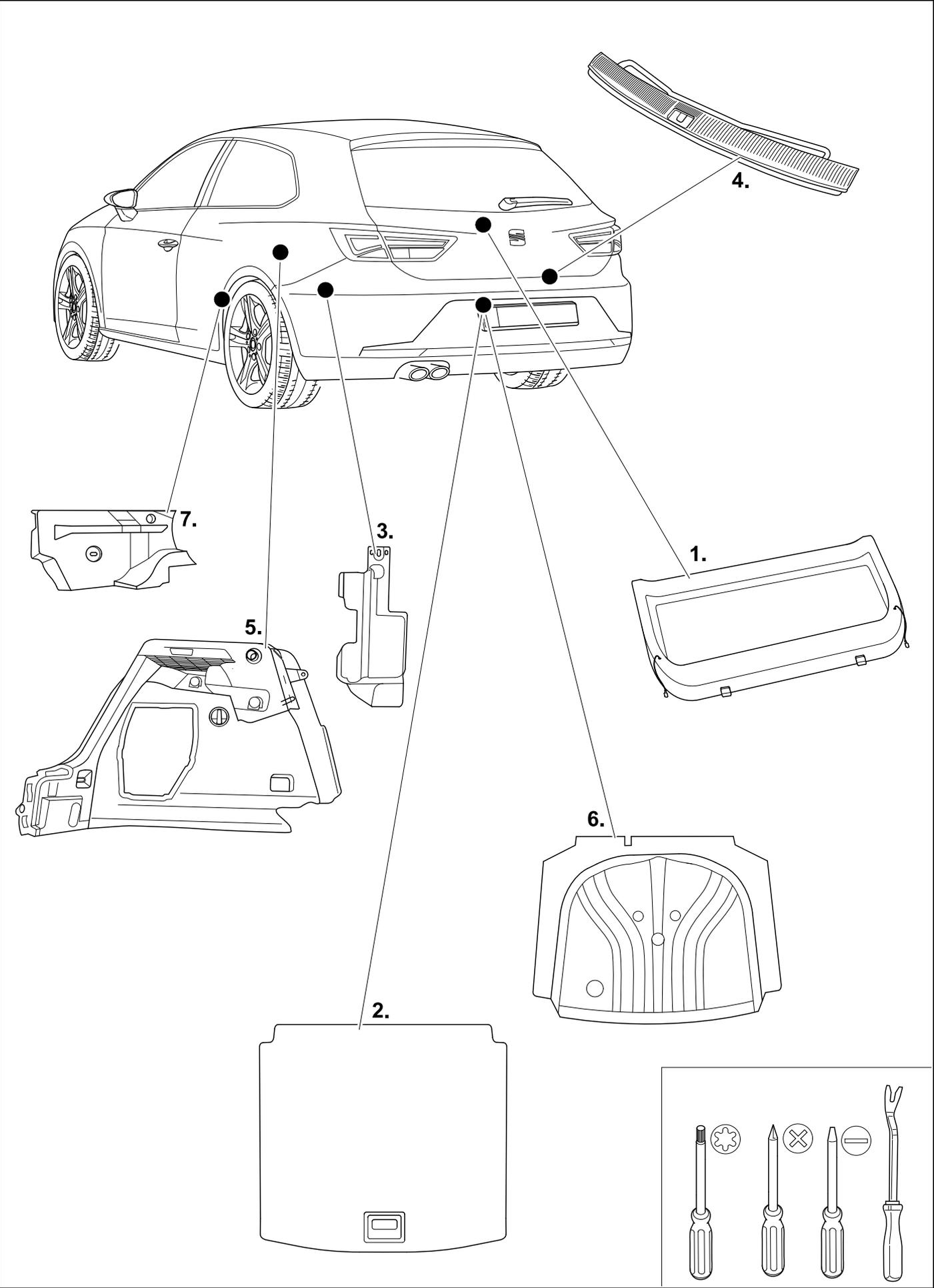

3 REMOVE

Leon PR: 1D0

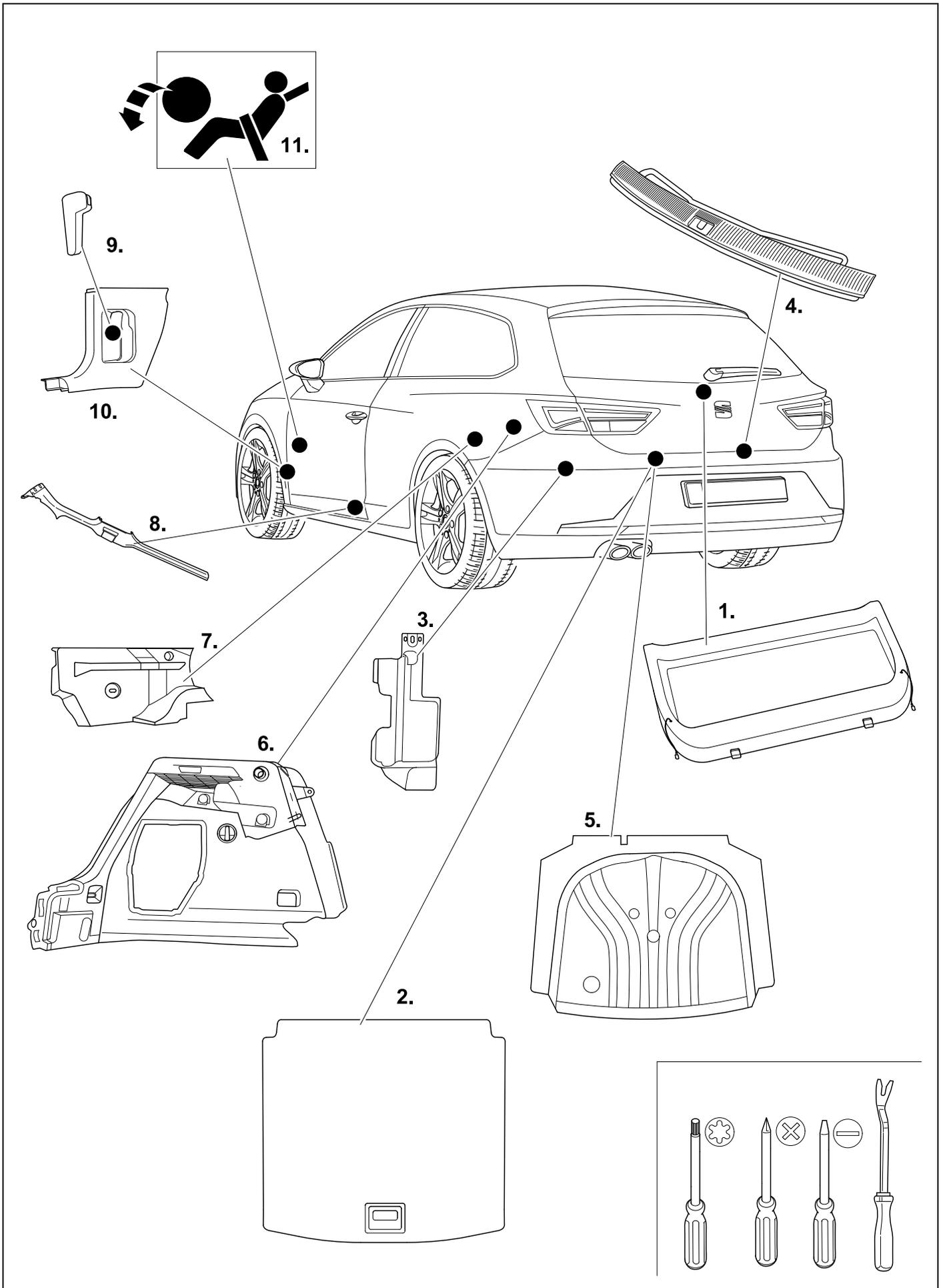

4 REMOVE

Leon ST / X-Perience PR: 1D8 / 1M5

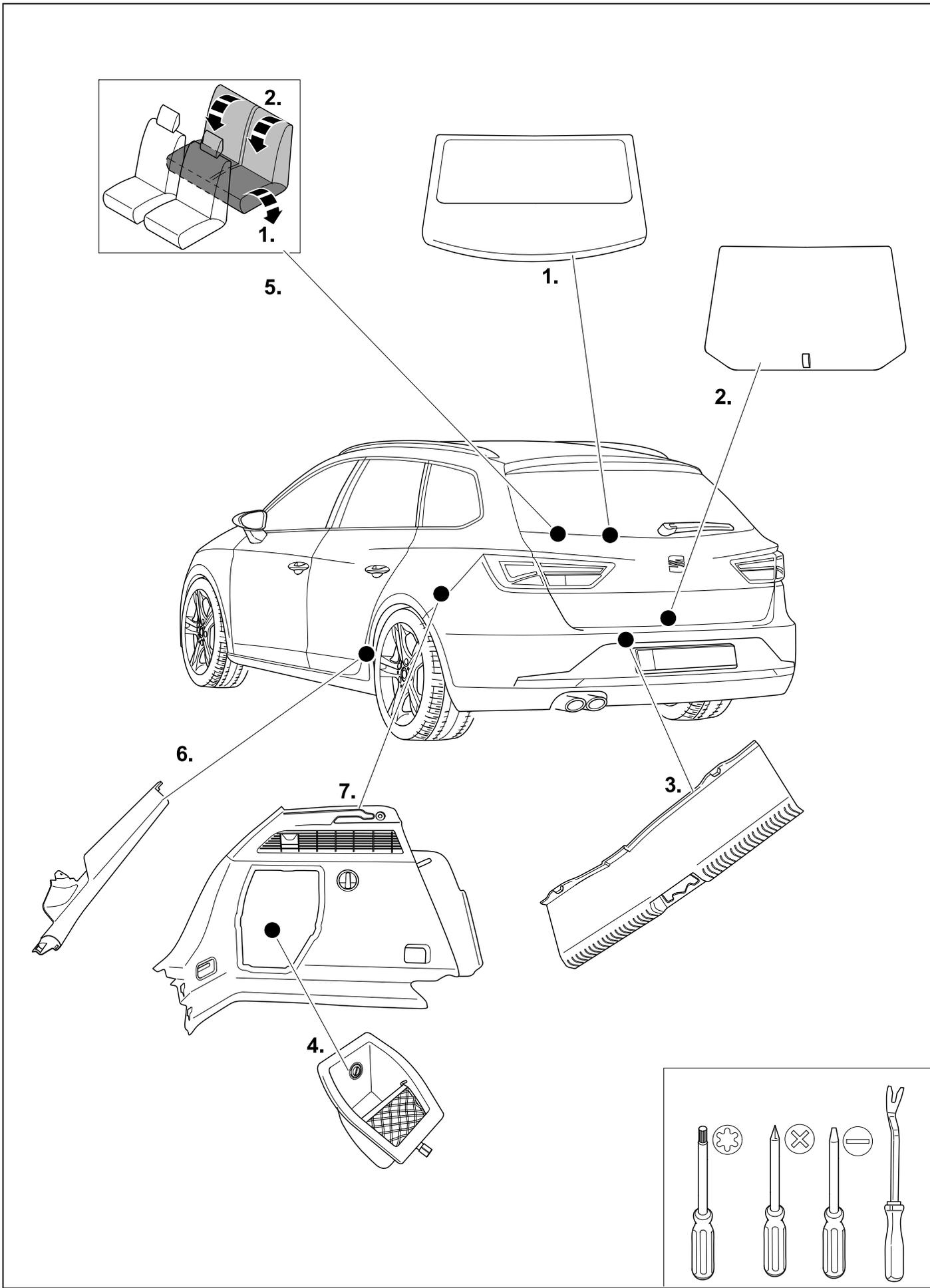

6

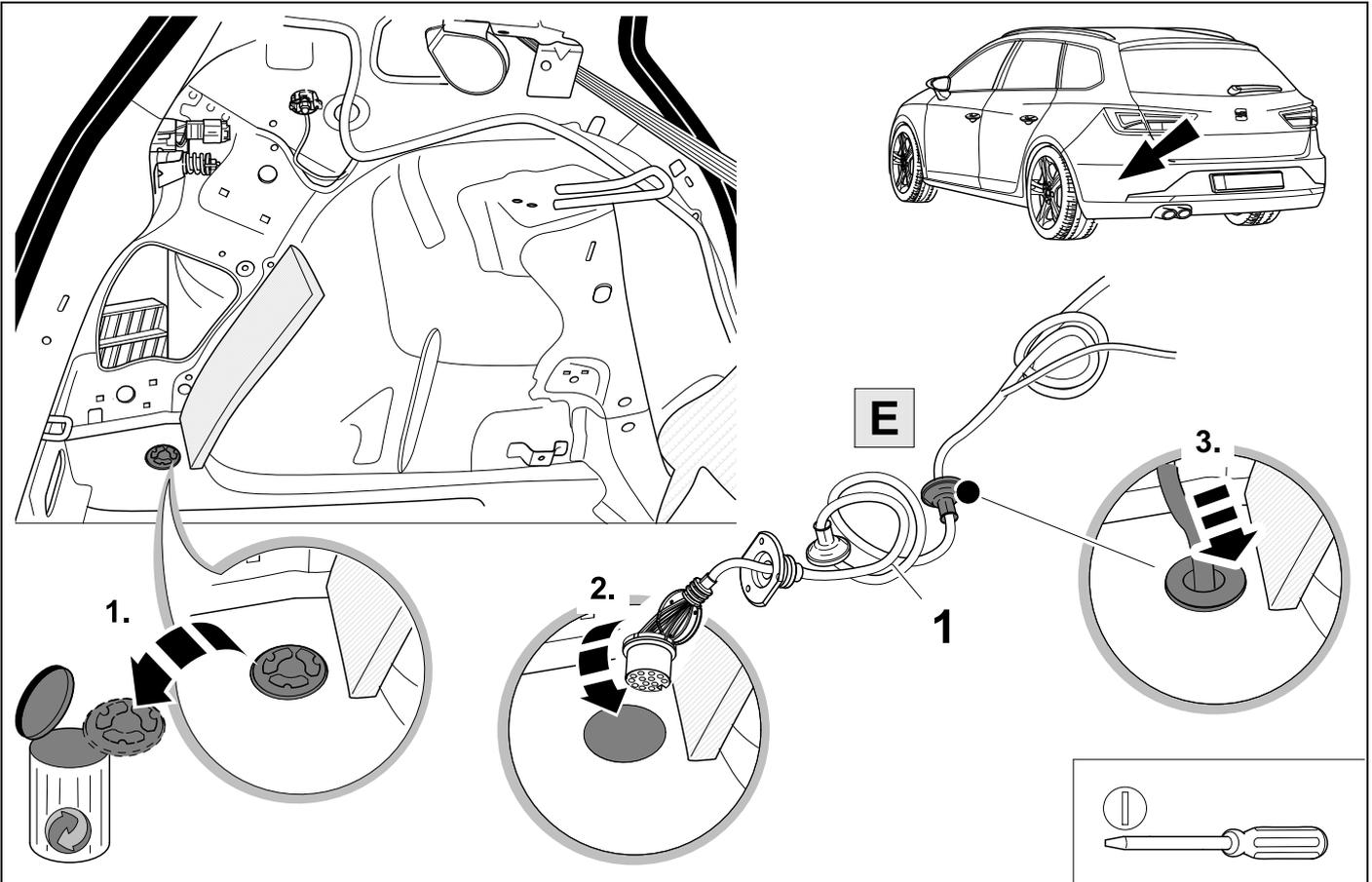

7

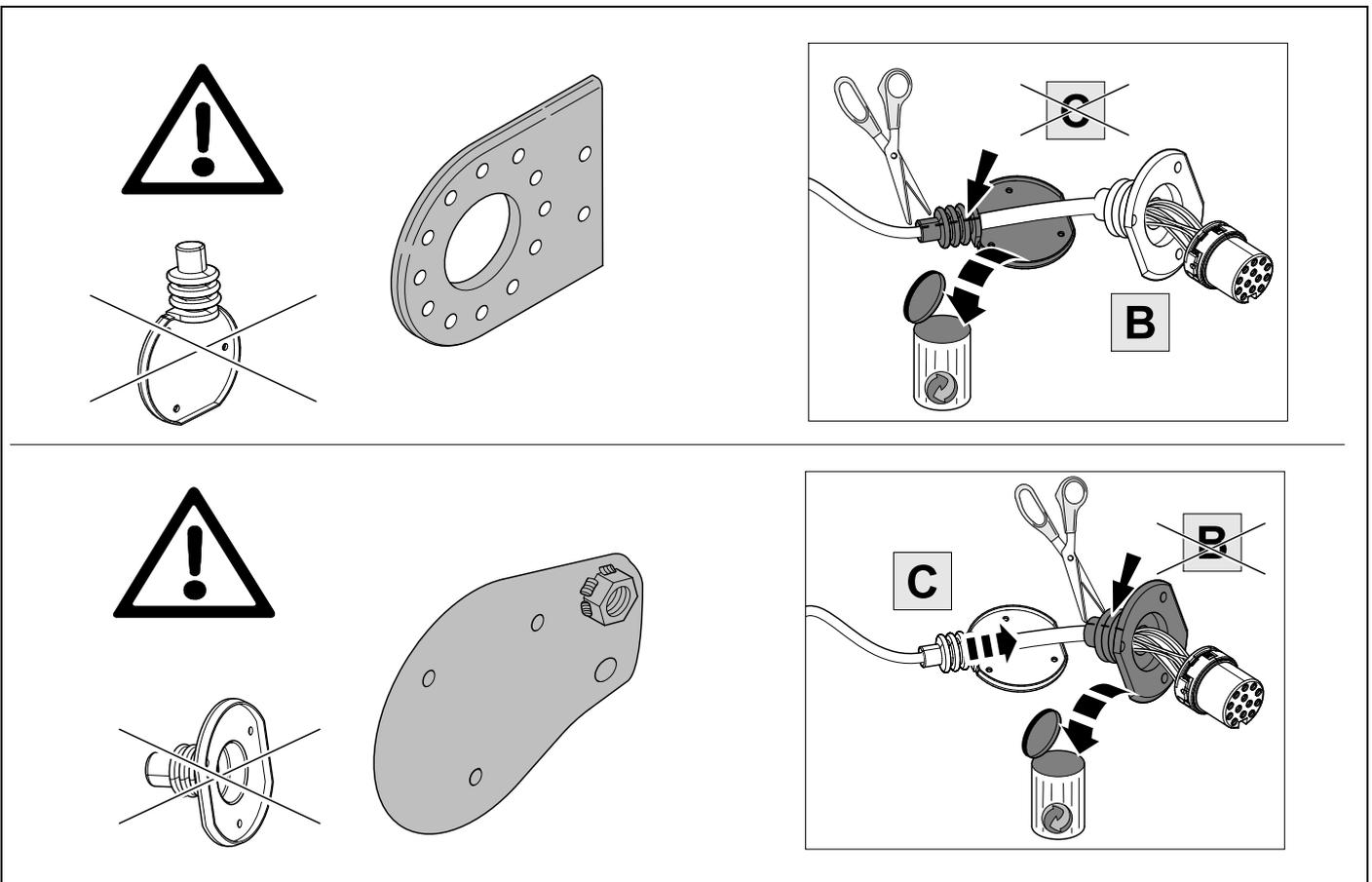

8



10

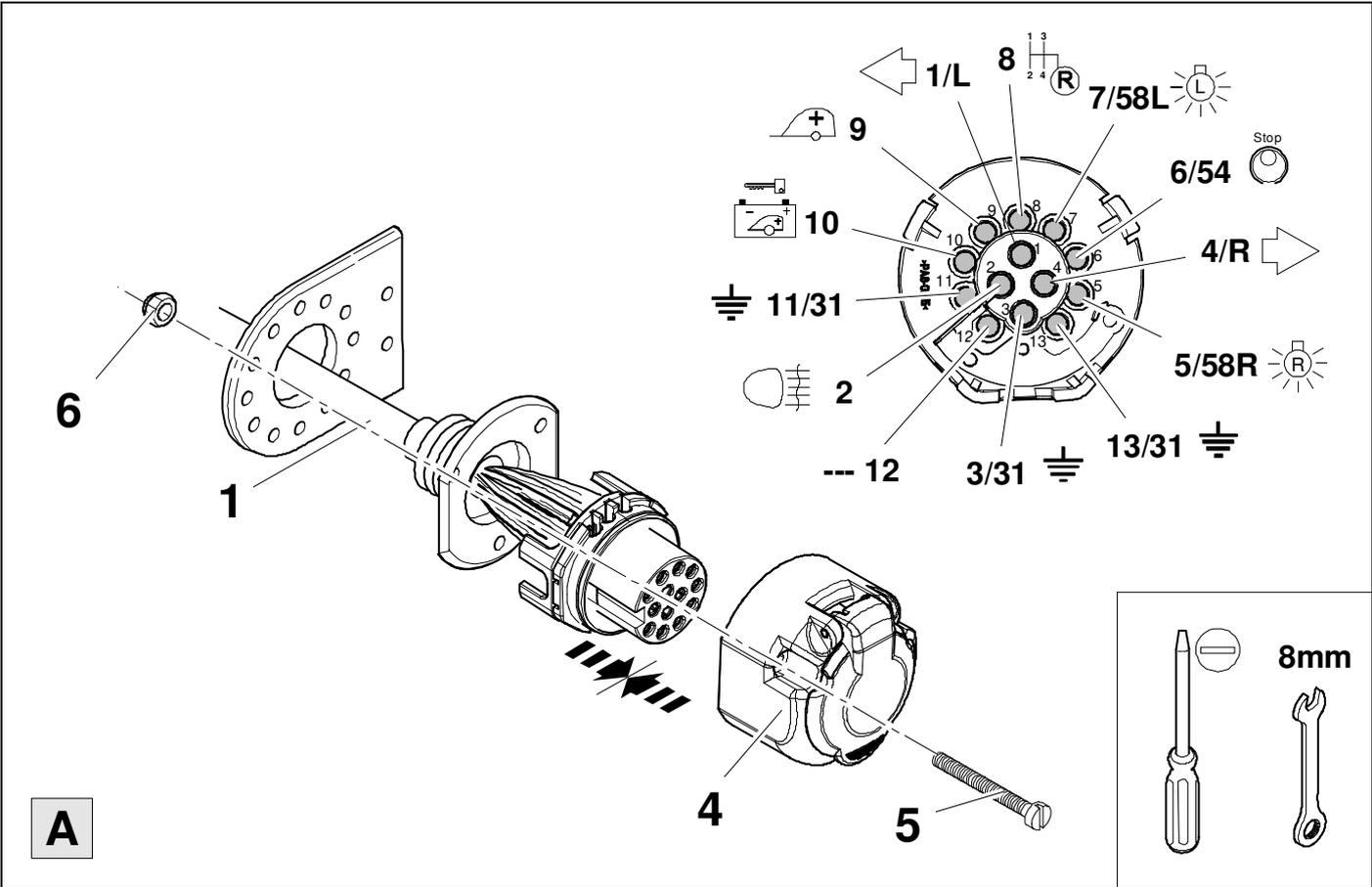

A

9



10

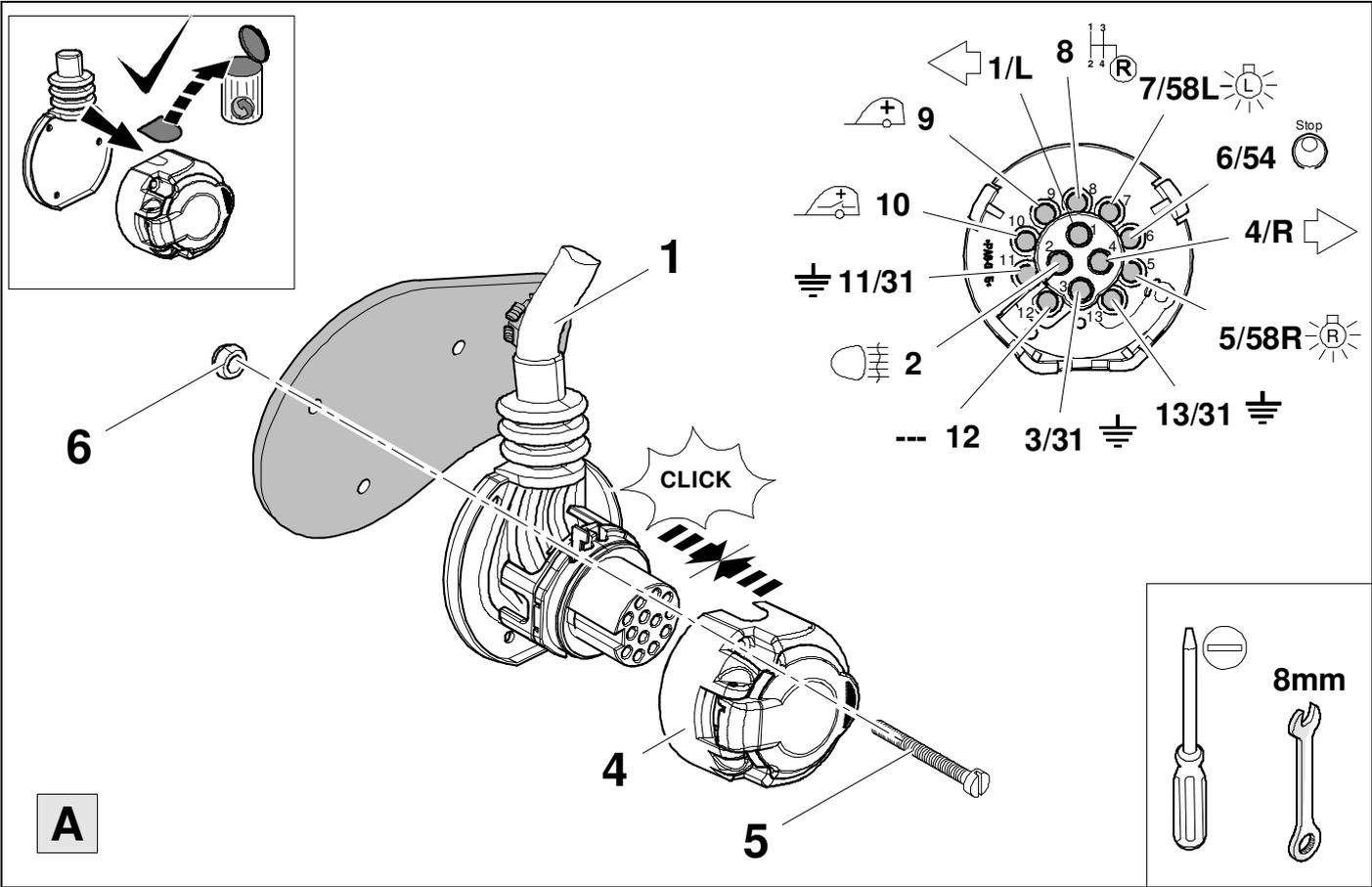

A



13 PIN

1	bk/wh		8	bu/rd	
2	gy		9	rd/bu	
3	wh/bn		10	ye	
4	bk/gn		11	bn/gn	
5	gy/rd		12	no	-/-
6	bk/rd		13	bn	
7	gy/bk				

11	bk	wh	gy	gn	rd	bu	ye	bn	pu	or	no
(D)	schwarz	weiß	grau	grün	rot	blau	gelb	braun	violett	orange	nicht belegt
(GB)	black	white	grey	green	red	blue	yellow	brown	purple	orange	not occupied
(F)	noir	blanc	gris	vert	rouge	bleu	jaune	brun	violet	orange	inutilisé
(NL)	zwart	wit	grijs	groen	rood	blauw	geel	bruin	violet	oranje	niet aangesloten
(DK)	sort	hvid	grå	grøn	rød	blå	gul	brun	violet	orange	ikke anvendt
(N)	svart	hvit	grå	grønn	rød	blå	gul	brun	fiolett	oransje	ikke i bruk
(S)	svart	vit	grå	grön	röd	blå	gul	brun	violett	orange	ej använd
(FIN)	musta	valkoinen	harmaa	vihreä	punainen	sininen	keltainen	ruskea	violetti	oranssi	ei varattu
(I)	nero	bianco	grigio	verde	rosso	blu	giallo	marrone	viola	arancione	libero
(E)	negro	blanco	gris	verde	rojo	azul	amarillo	marrón	violeta	anaranja-do	no ocupado
(P)	preto	branco	cinzento	verde	vermelho	azul	amarelo	castanho	violeta	laranja	não ocupado
(GR)	μαύρος	λευκός	Γκρι	πράσινος	κόκκινος	μπλε	κίτρινος	καφέ	Μωβ	πορτοκαλί	δεν είναι κατ'επιτημένως
(PL)	czarny	biały	szary	zielony	czerwony	niebiesko	żółty	brazowy	fioletowy	pomarańczowy	wolny
(CZ)	černý	bílý	šedý	zelený	červený	modrý	žlutý	hnědý	fialový	oranžový	neobsazen
(TR)	siyah	beyaz	gri	yeşil	kırmızı	mavi	sarı	kahverengi	mor	portakal rengi	boş
(H)	fekete	fehér	szürke	zöld	piros	kék	sárga	barna	ibolyakék	narancssárga	nem foglalt
(HR)	crno	bijelo	sivo	zeleno	crveno	plavo	zuto	smeđe	ljubičasto	narandasto	nije zauzeto
(BUL)	черен	бял	сив	зелен	червен	син	жълт	кафяв	виолетов	оранжев	свободно
(RO)	negru	alb	gri	verde	roșu	albastru	galben	maro	violet	portocaliu	liber
(RU)	черный	белый	серый	зеленый	красный	голубой	жёлтый	коричневый	пурпурный	оранжевый	свободно
(LT)	juoda	balta	pilka	žalia	raudona	mėlyna	geltona	ruda	purpurinė	oranžinė	laisva
(LV)	melna	balta	pelēka	zaļa	sarkana	zila	dzeltena	brūna	purpur-sarkana	oranža	brīvs
(EST)	must	valge	hall	roheline	punane	sinine	kollane	pruun	purpur-punane	oraanž	vaba
(SLO)	črna	bela	siva	zelena	rdeča	modra	rumena	smeđ	vijoličast	oranžen	ni zasedeno
(SK)	čierny	biely	šedý	zelený	červený	modrý	žltý	hnědý	fialový	pomaraňový	neobsadený

12

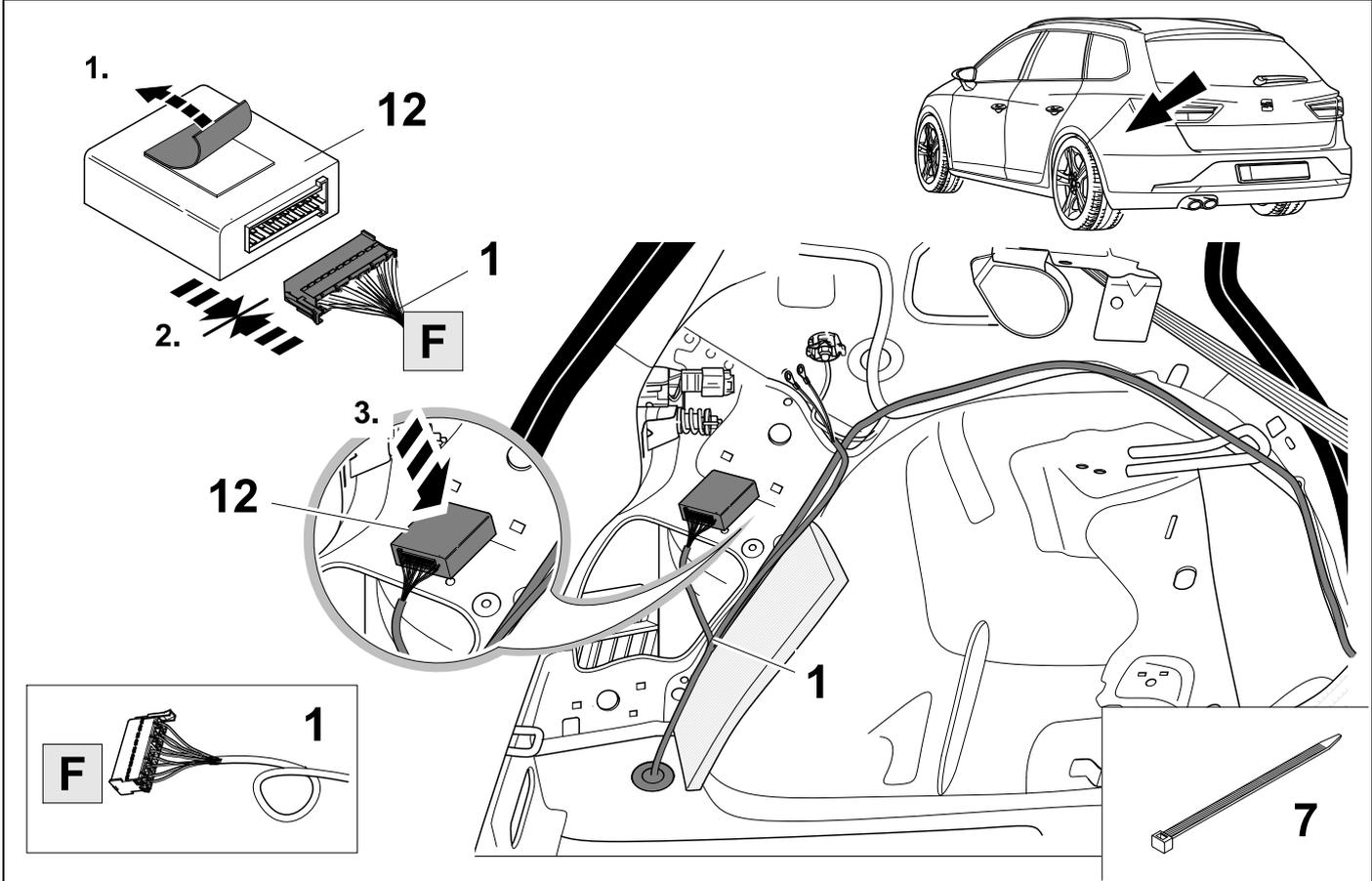

13

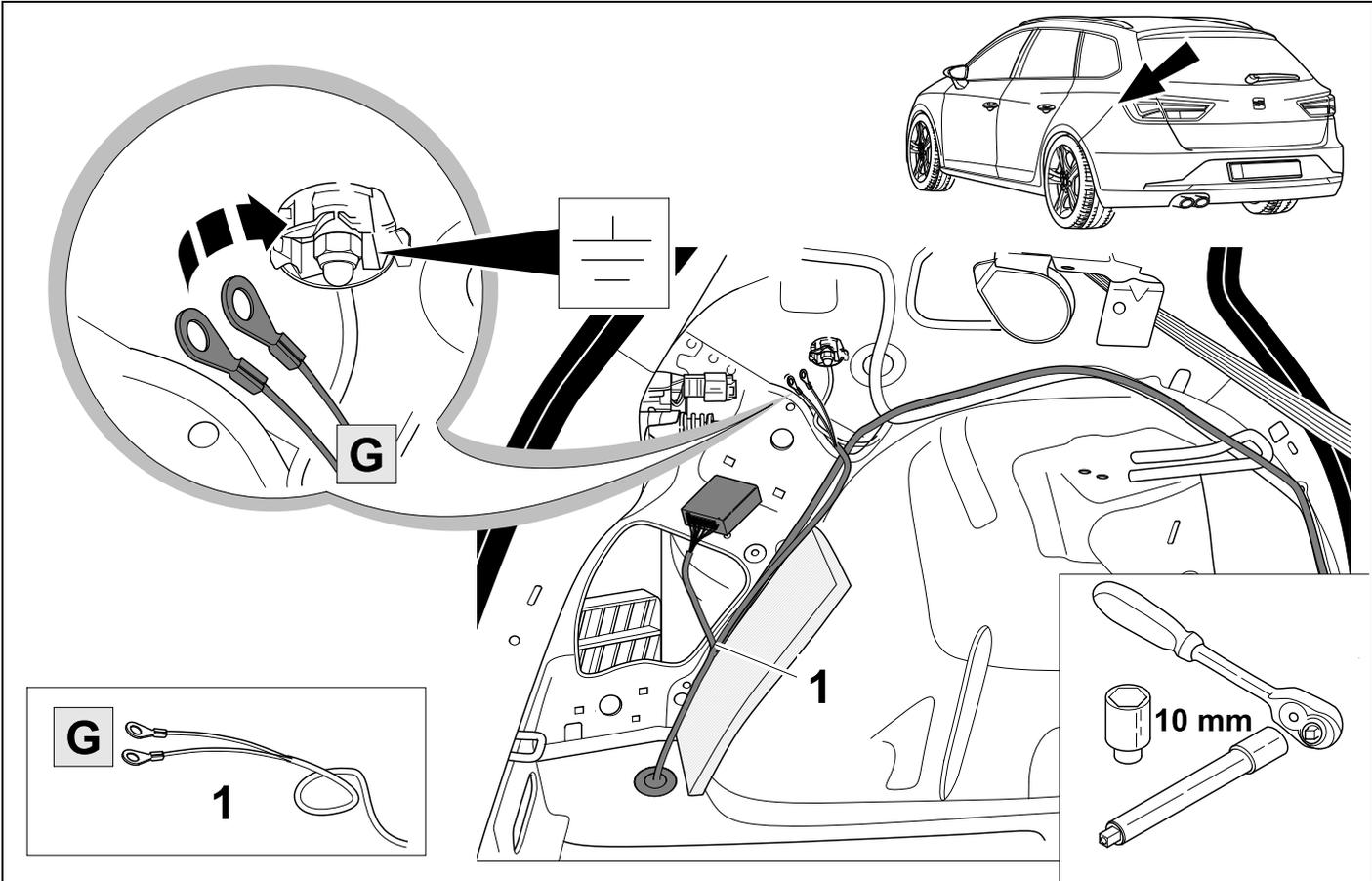

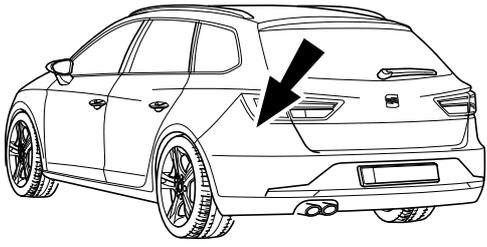

Vehicles without trailer preparation PR: 1D0

OPTION 1

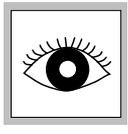
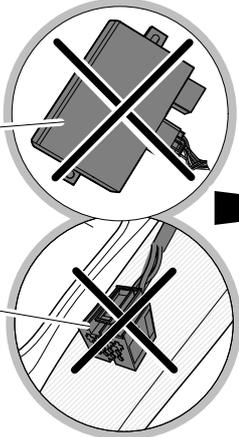
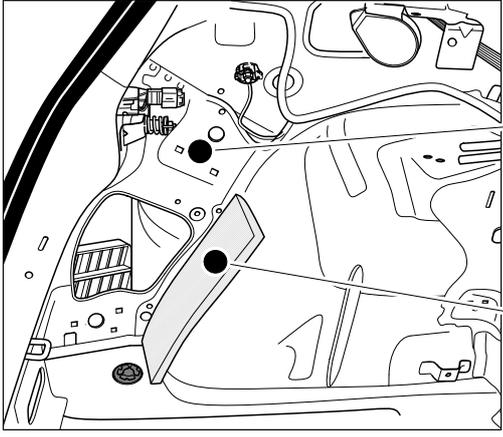

16 ⇨ 29

+
40 ⇨ 51

Vehicles with trailer preparation PR: 1D8

OPTION 2

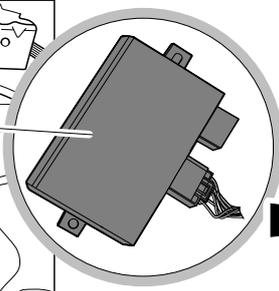
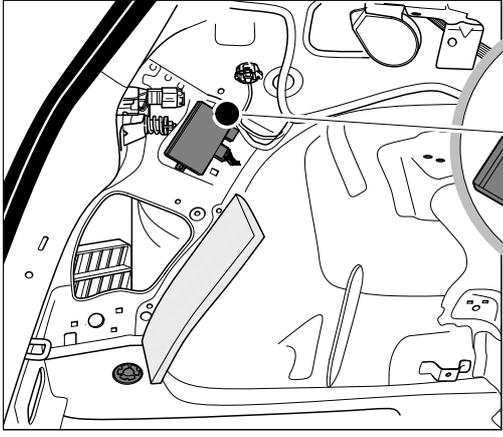

30

+
OPTION 3

31 ⇨ 32

+
40 ⇨ 51

Vehicles with trailer preparation PR: 1M5

OPTION 3

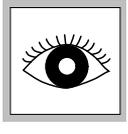
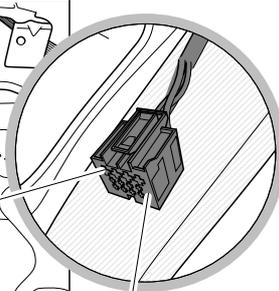
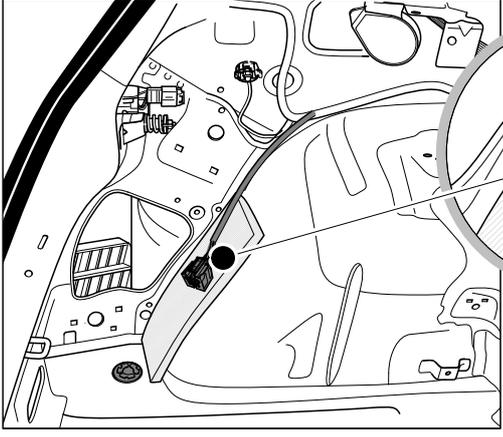

rd
12 PIN

31 ⇨ 32

+
39 ⇨ 51

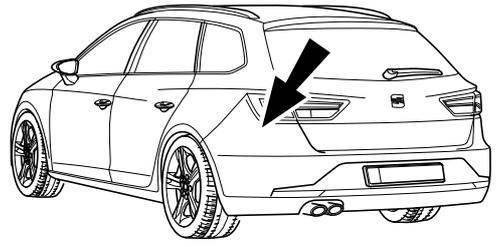

Vehicles without trailer preparation PR: 1D0

OPTION 1

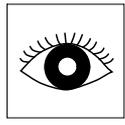
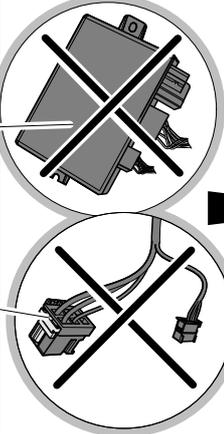
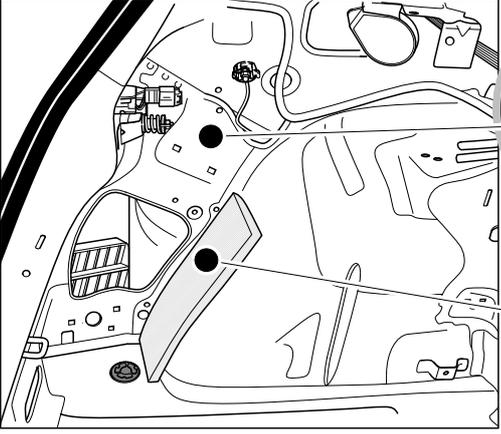

16 ⇨ 29

+
40 ⇨ 51

Vehicles with trailer preparation PR: 1D8

OPTION 4

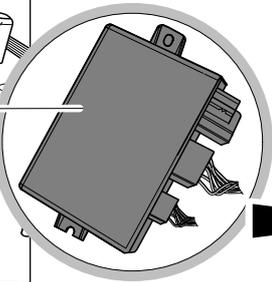
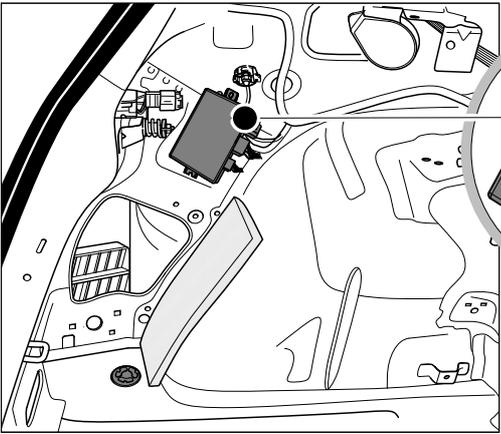

33

+
OPTION 5

34 ⇨ 38

+
40 ⇨ 51

Vehicles with trailer preparation PR: 1M5

OPTION 5

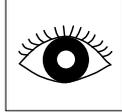
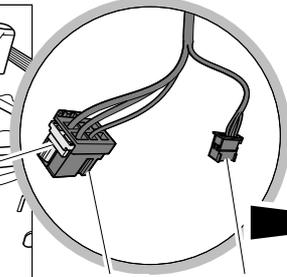
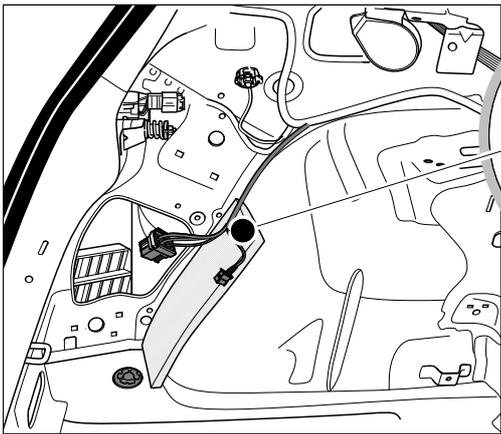

34 ⇨ 51

bk 6 PIN bk 10 PIN

16

OPTION 1

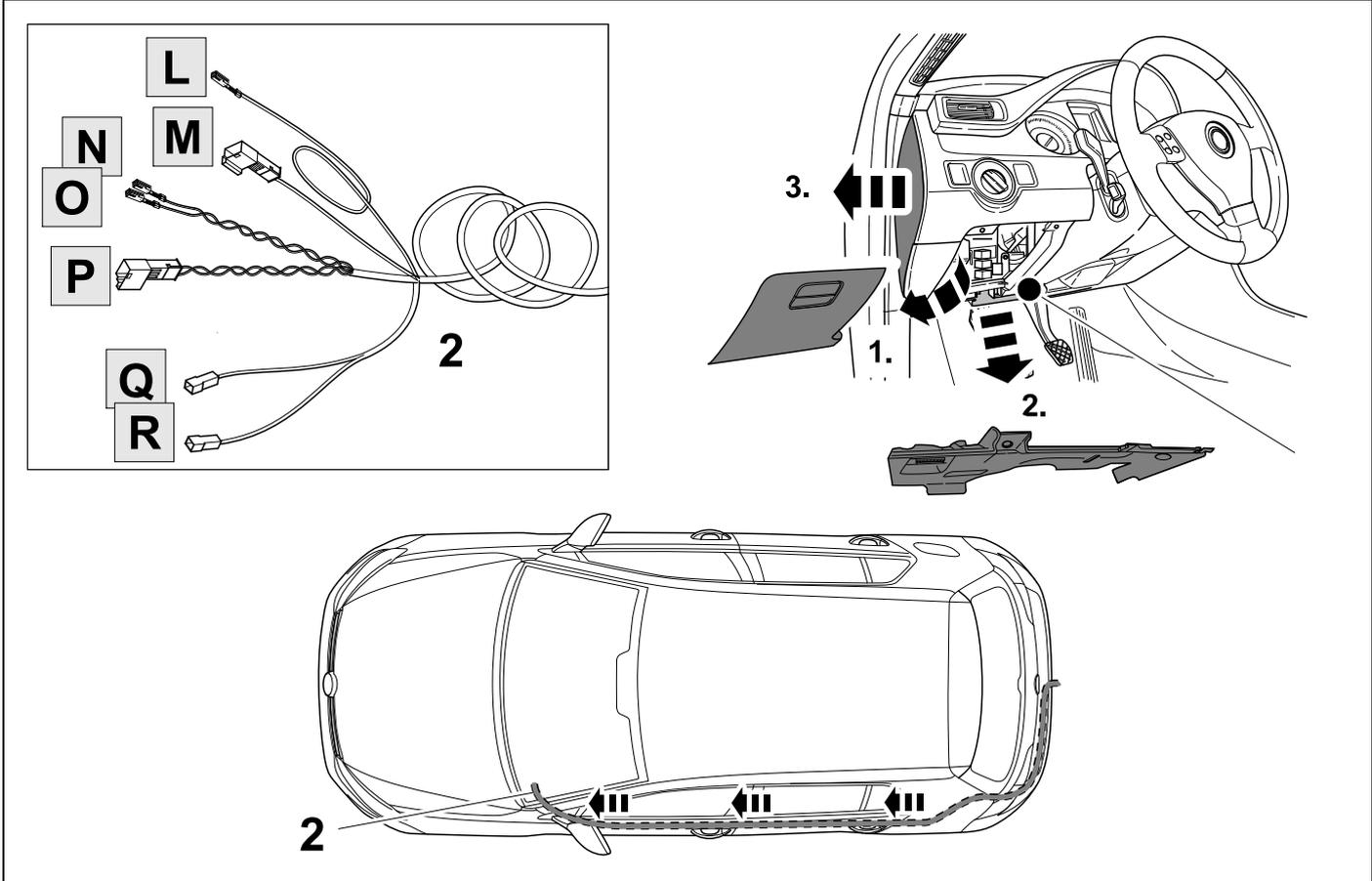

17

👁️ ⇒ 11 + 45

OPTION 1

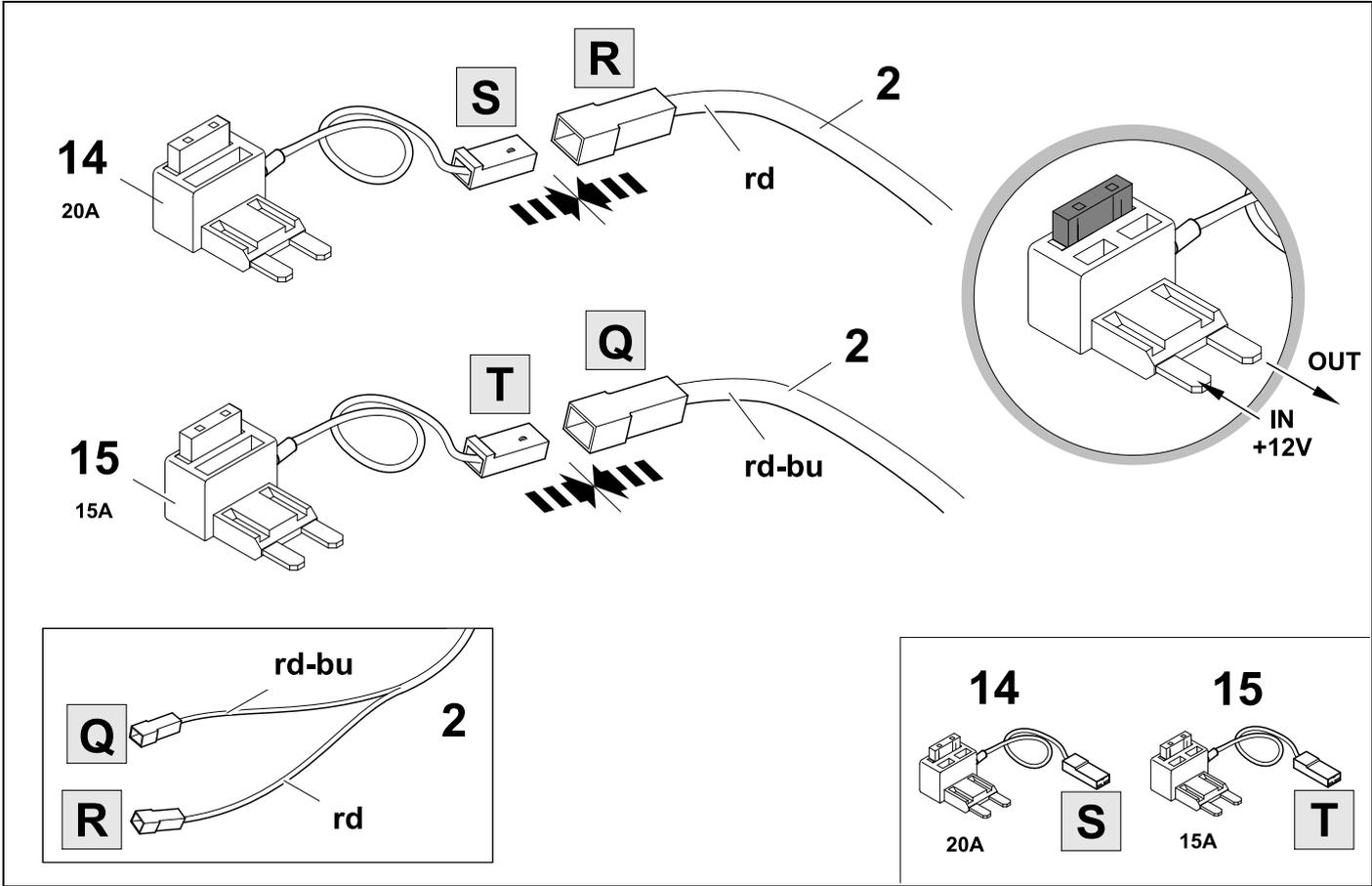

18



45

OPTION 1

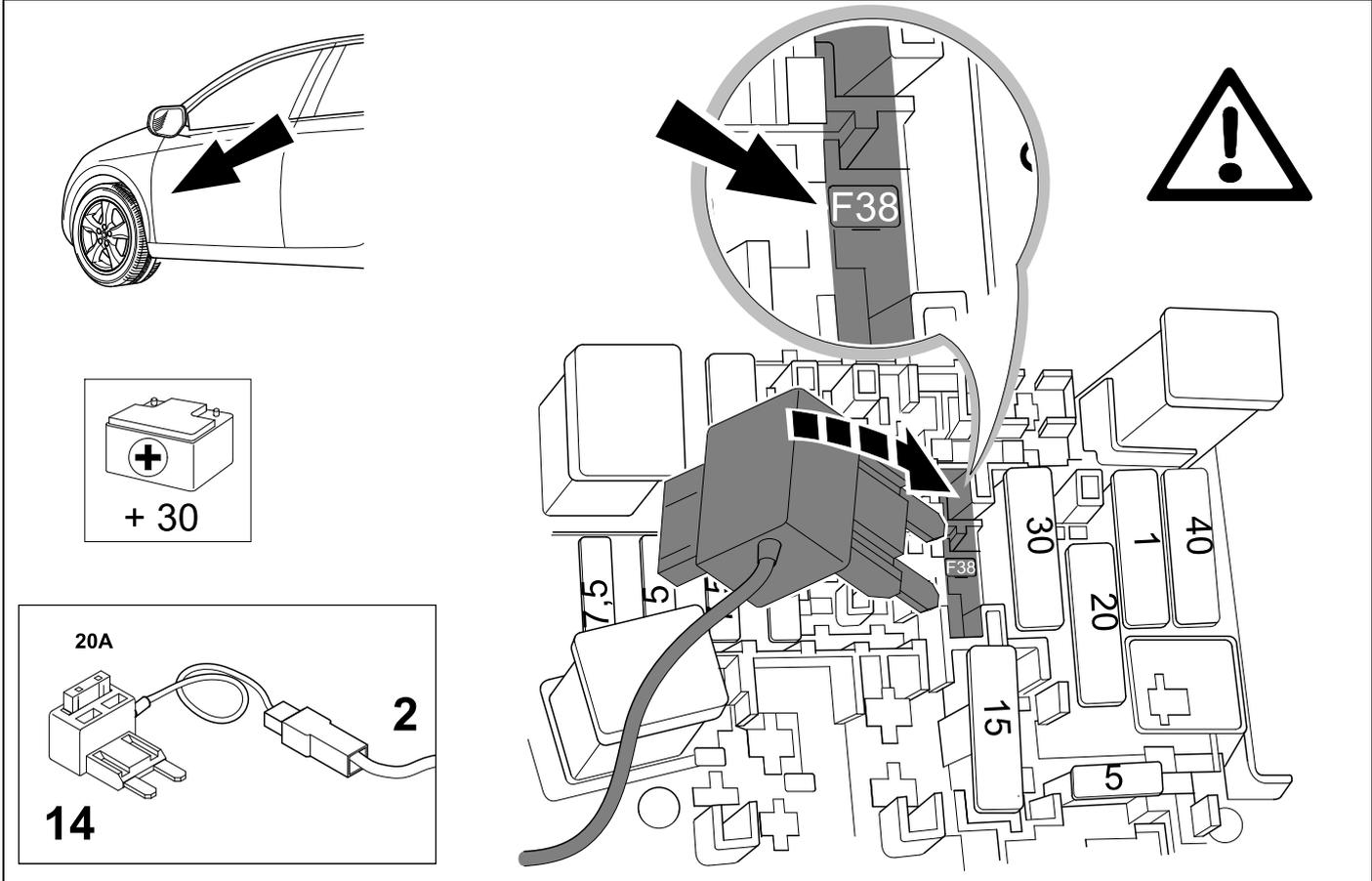

19



45

OPTION 1

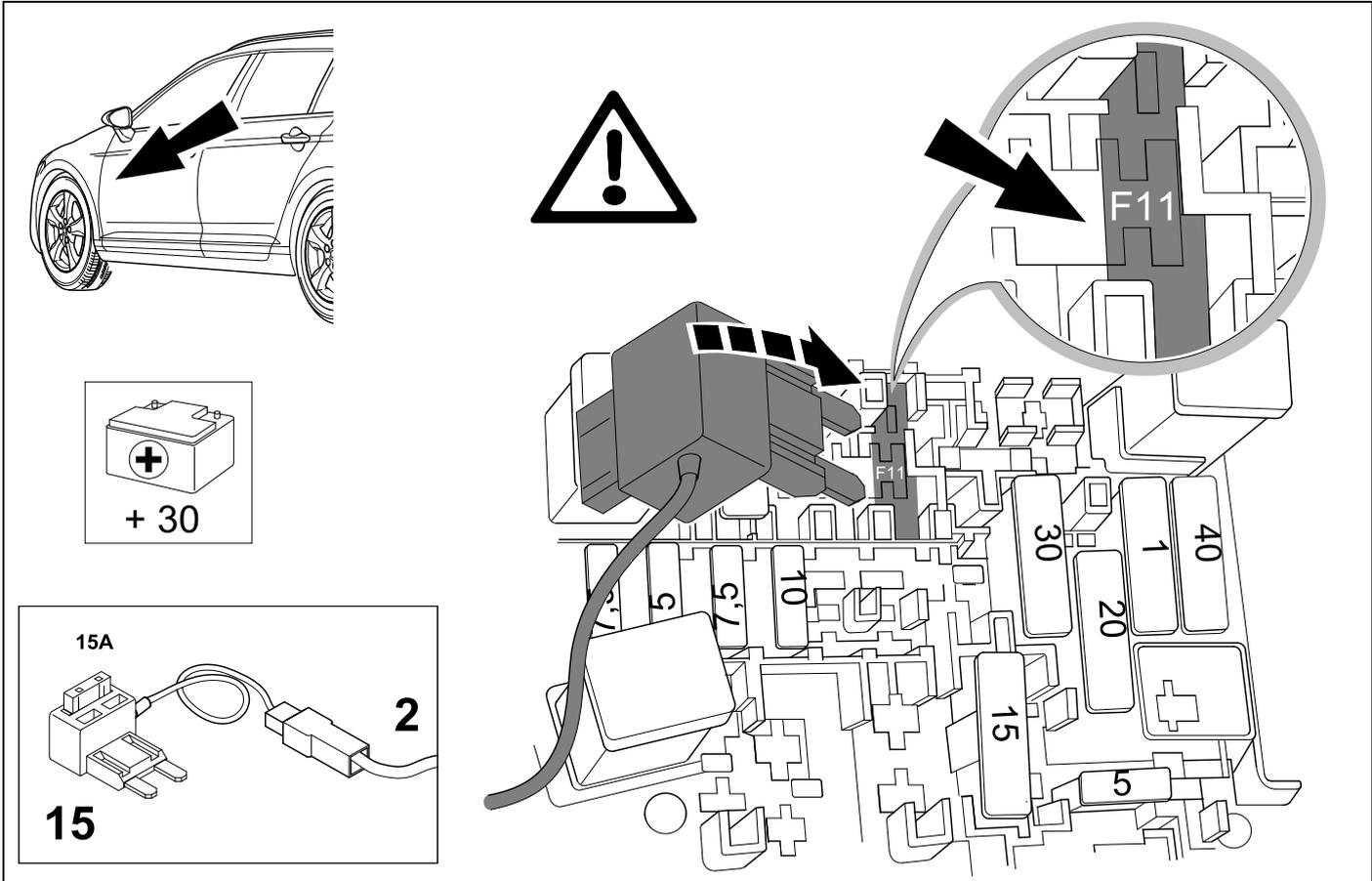

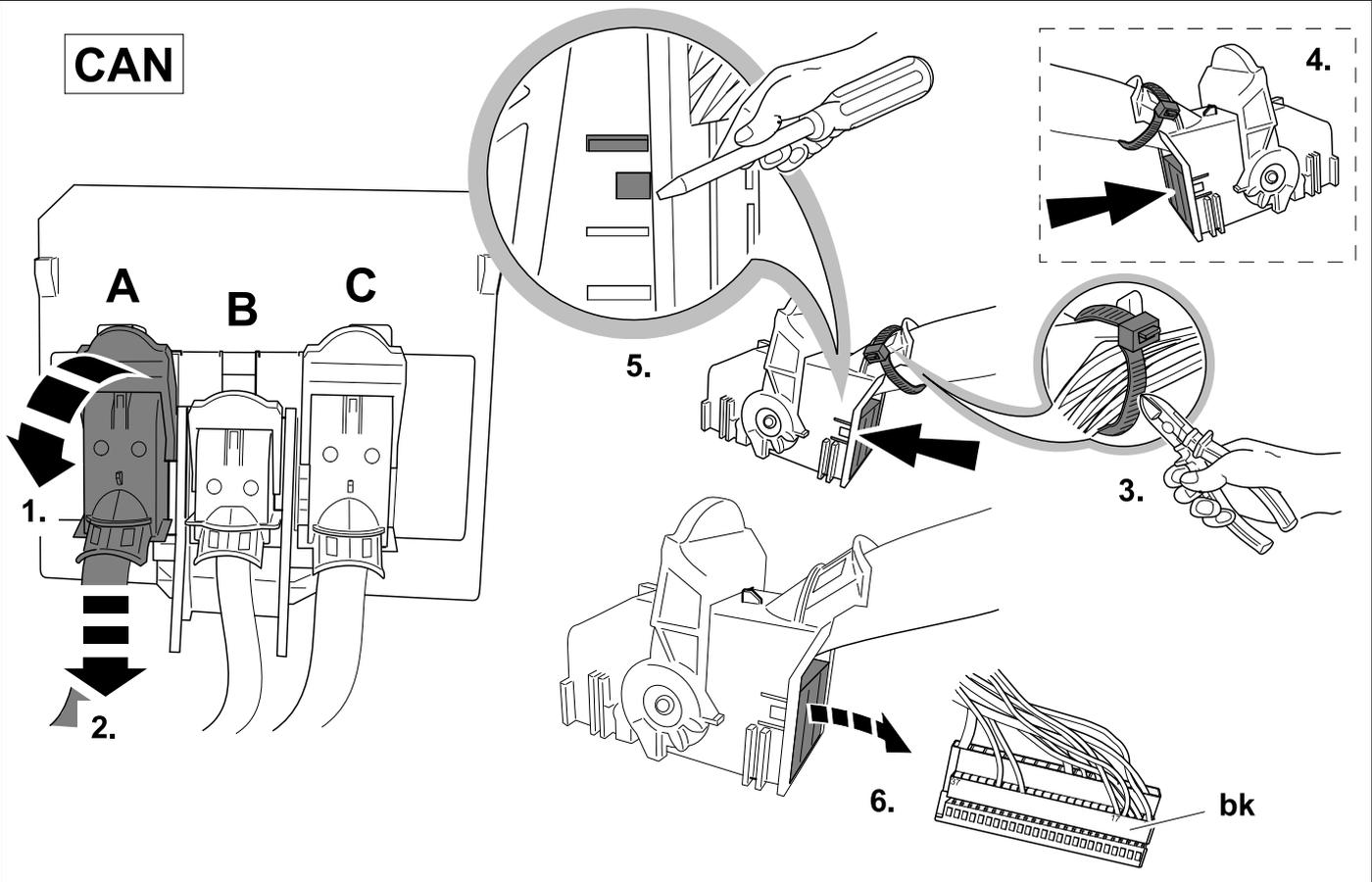
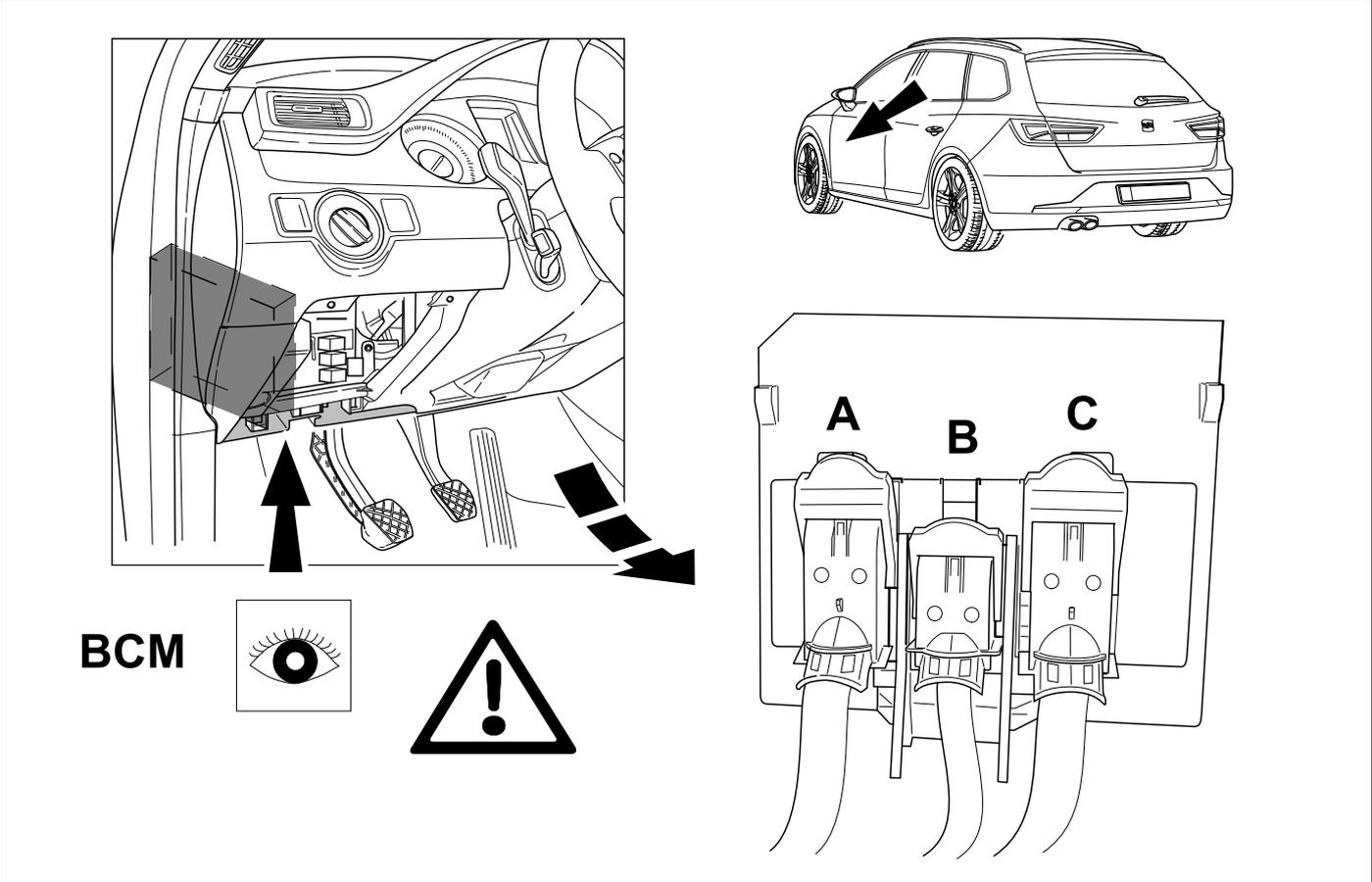

22



11

OPTION 1

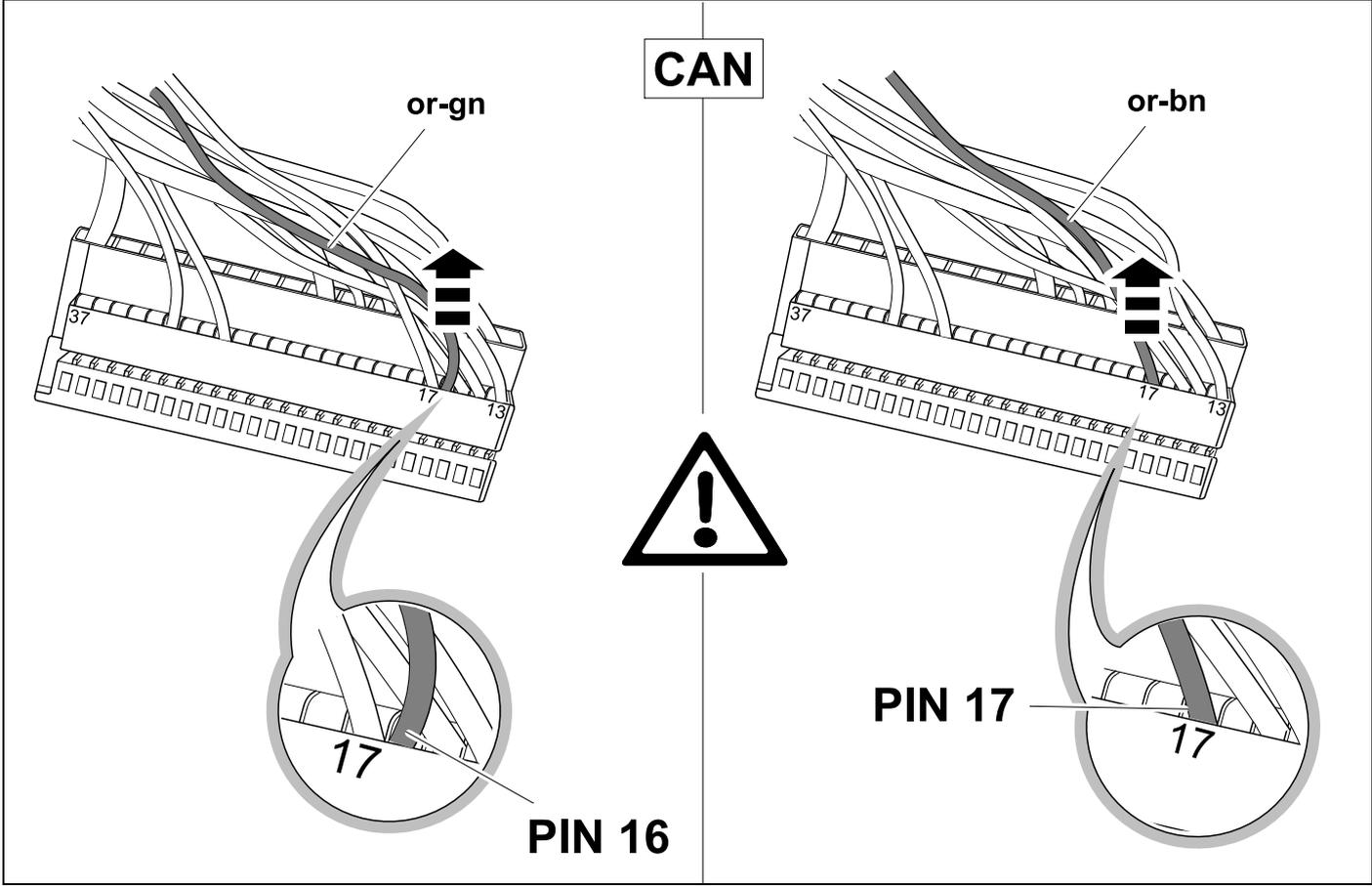

23



11

OPTION 1

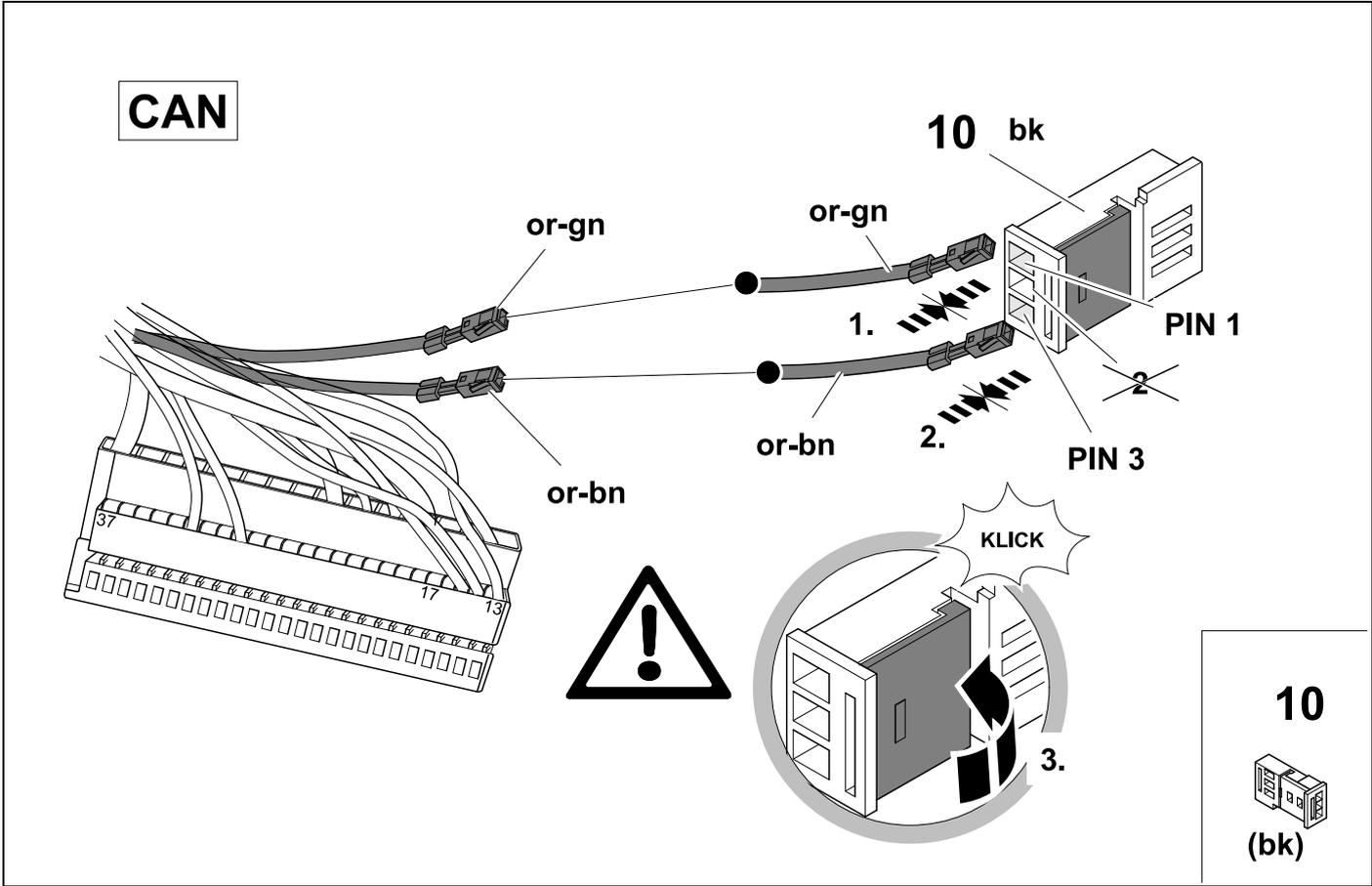

CAN

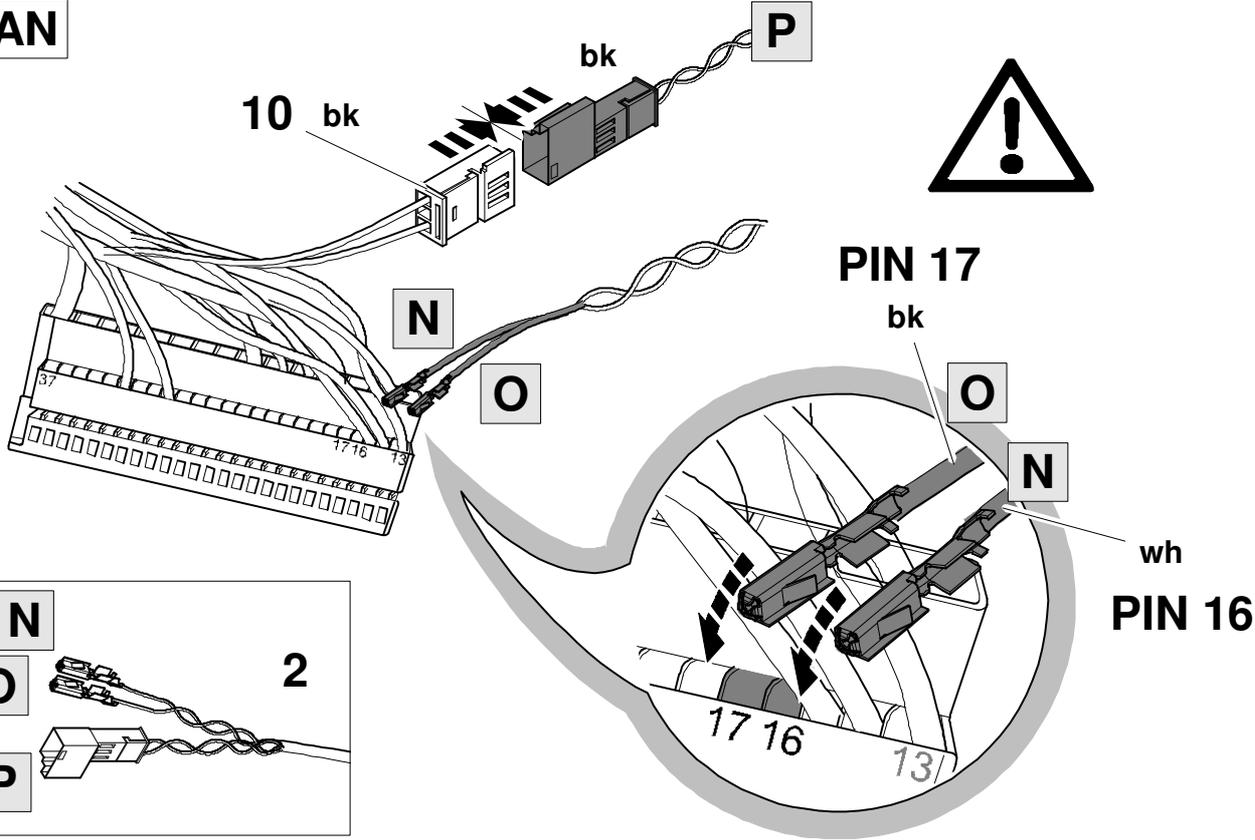

CAN

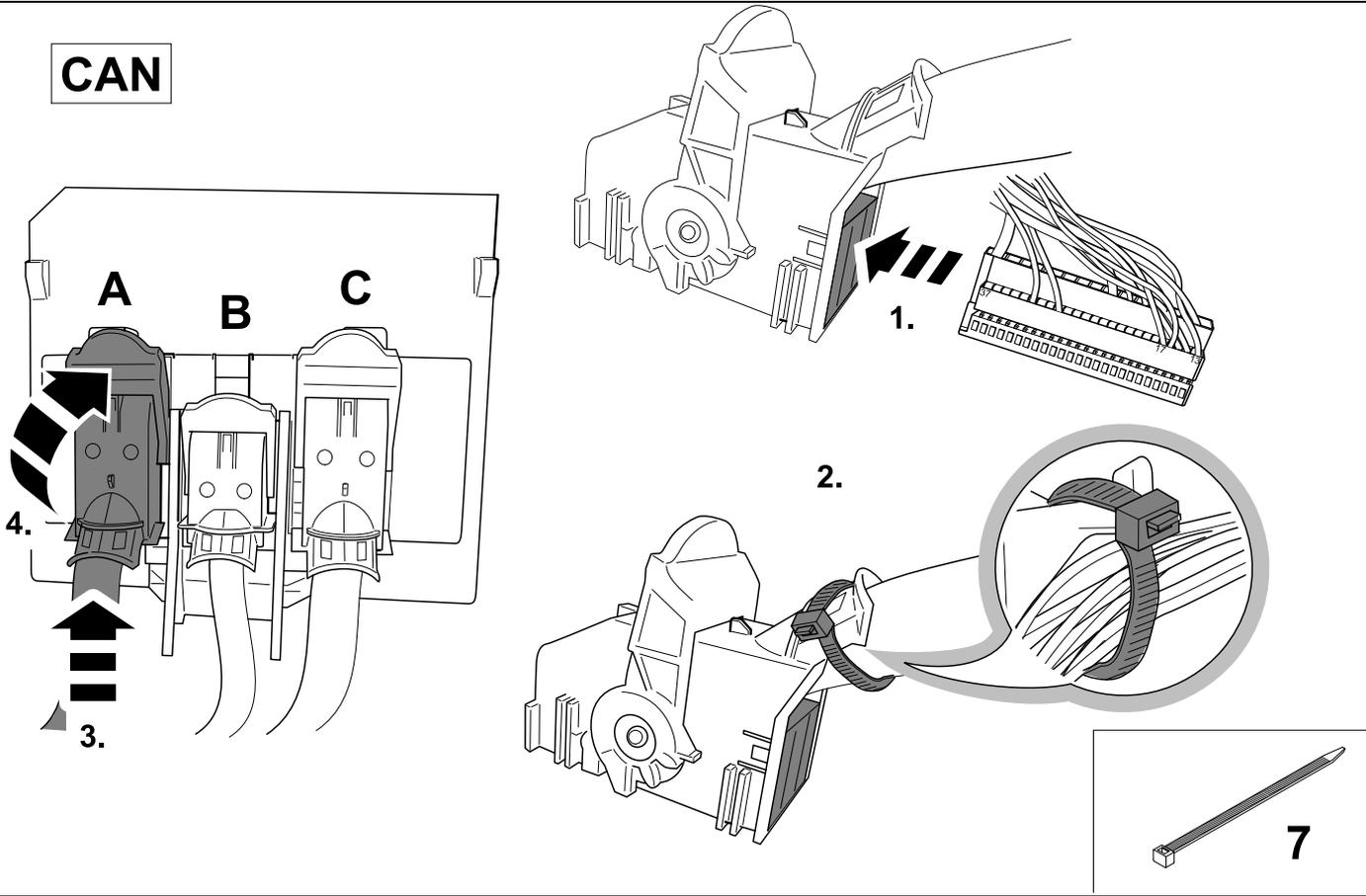

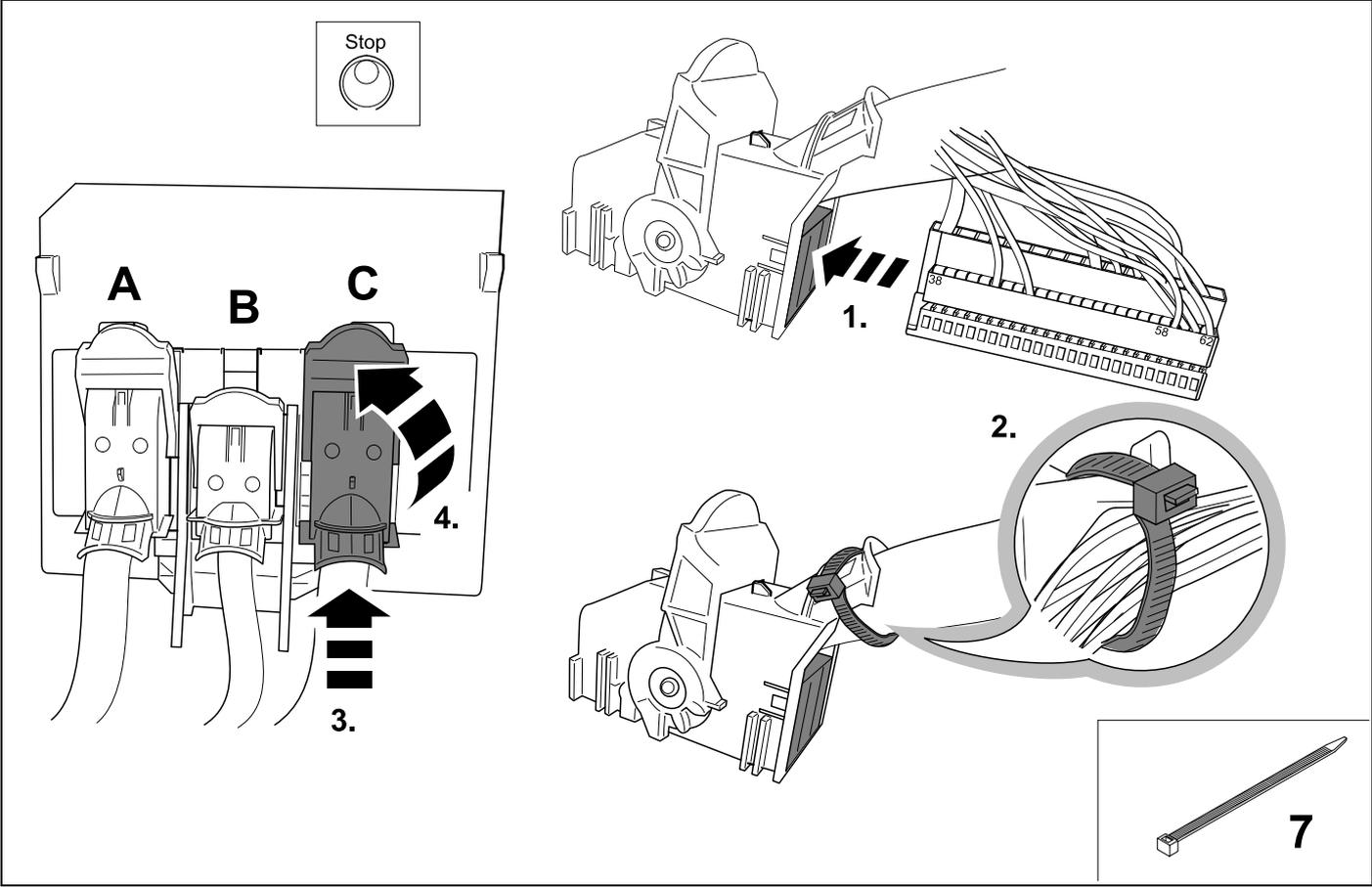
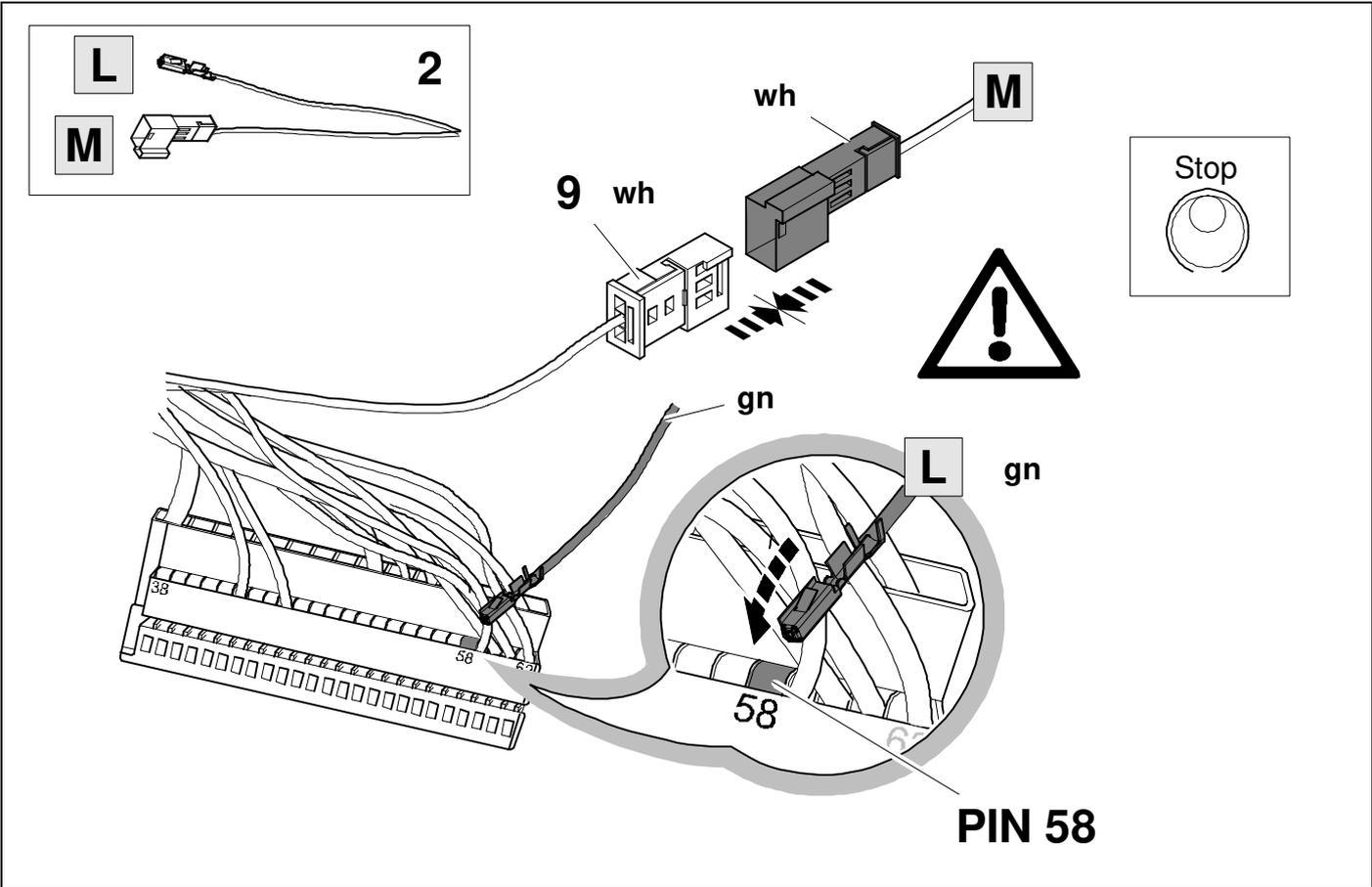

30



⇒ 11

OPTION 2

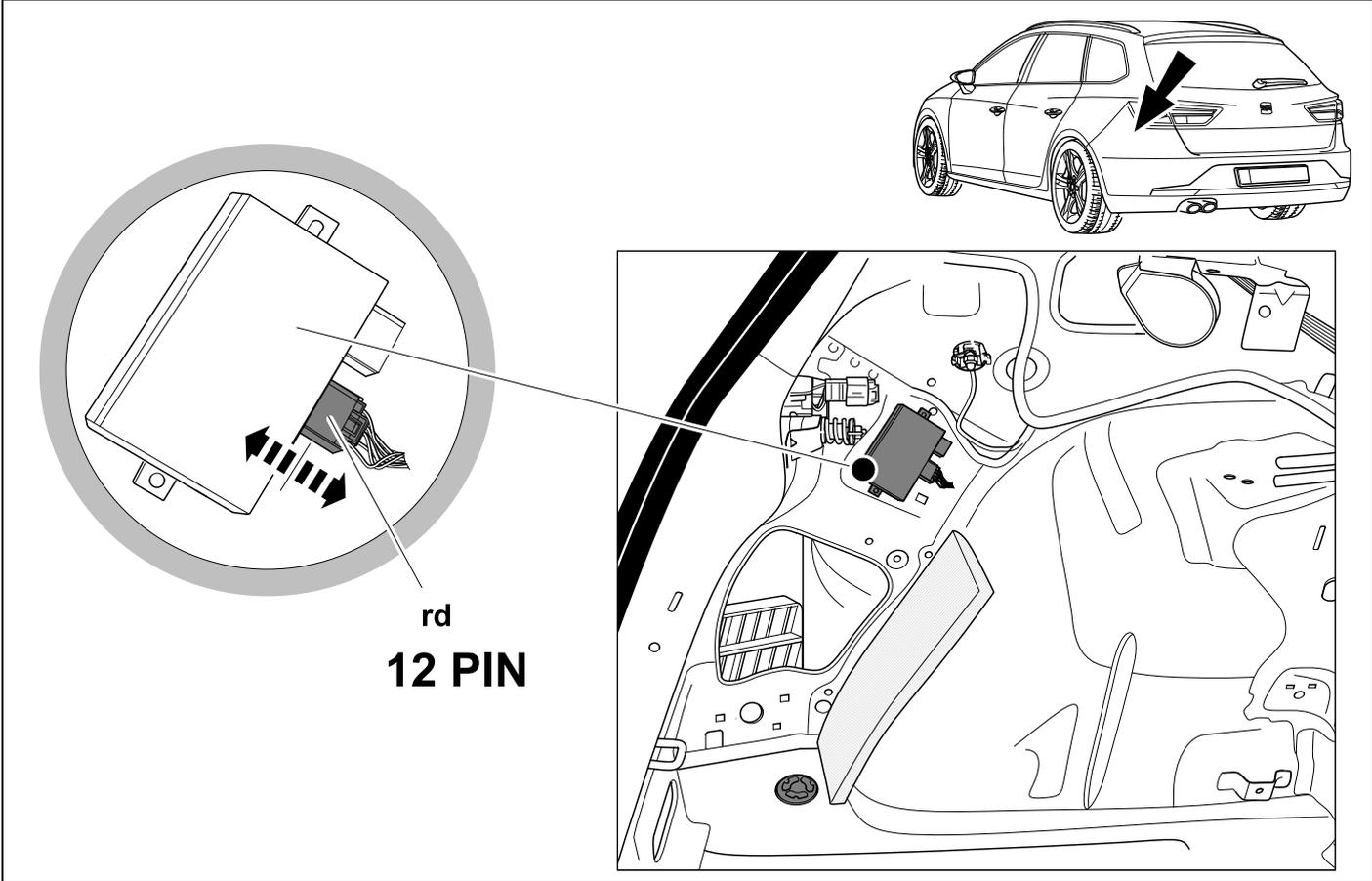

31



⇒ 11

OPTION 3

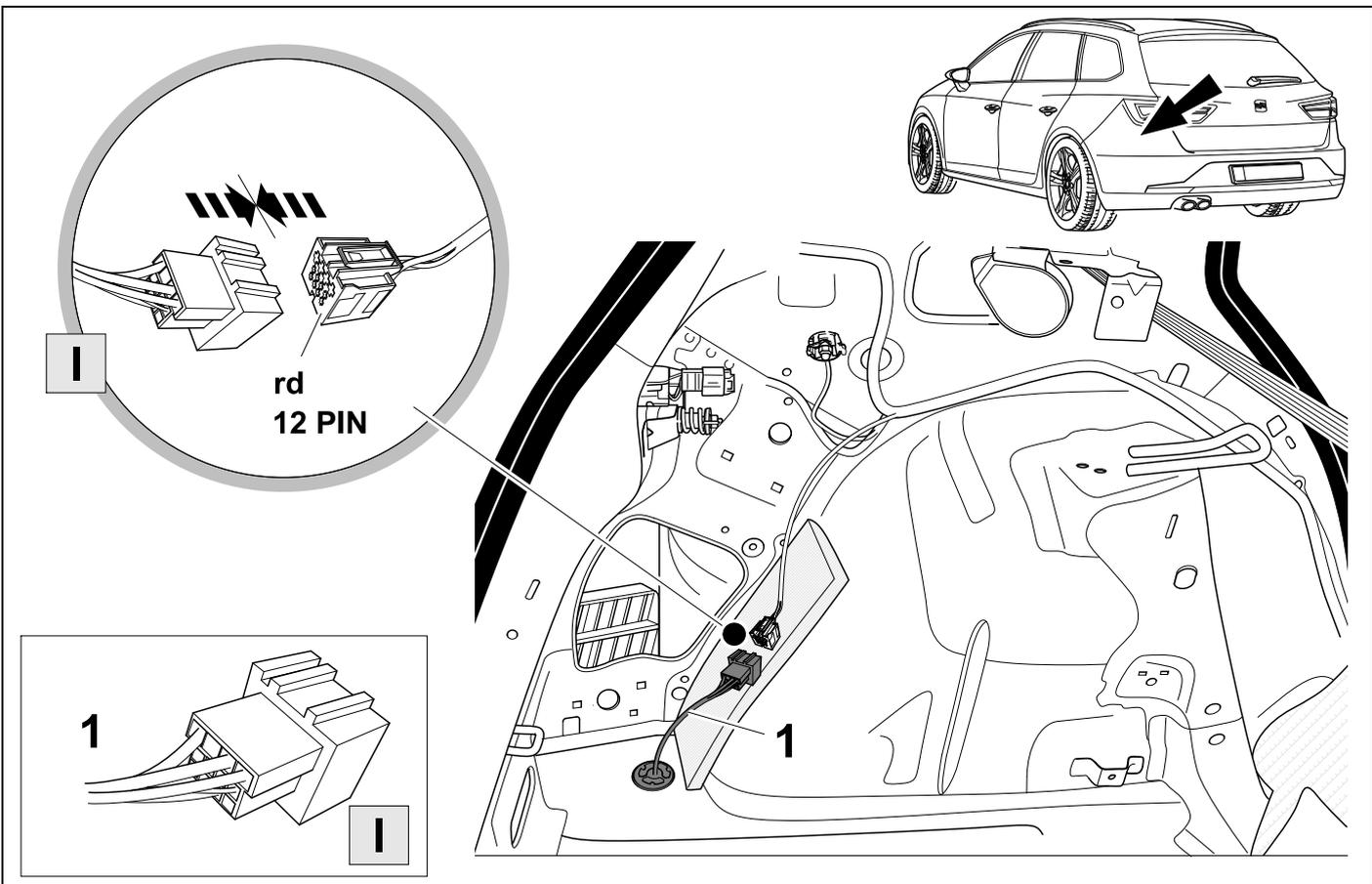

32



11

OPTION 3

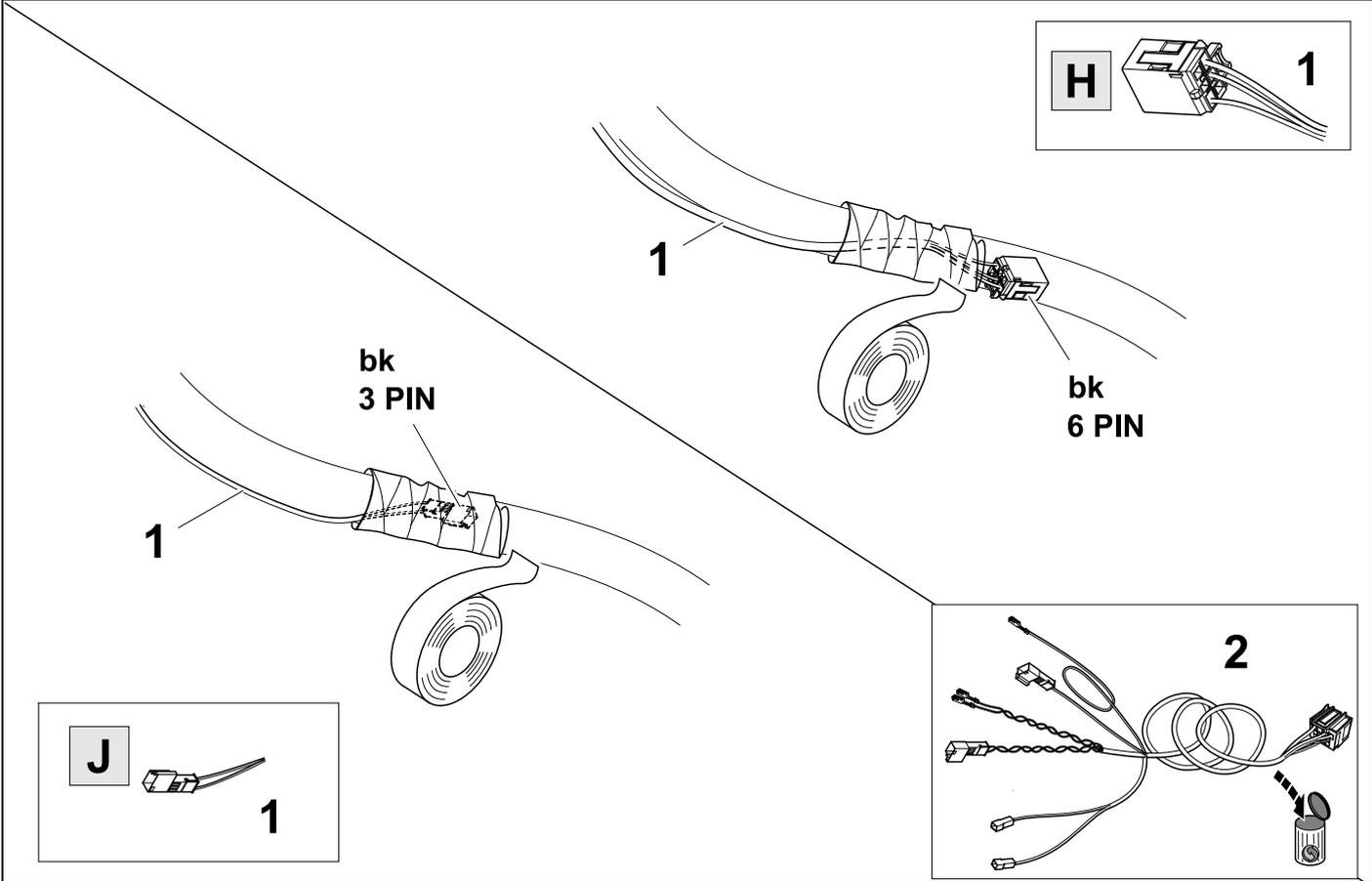

33



11

OPTION 4

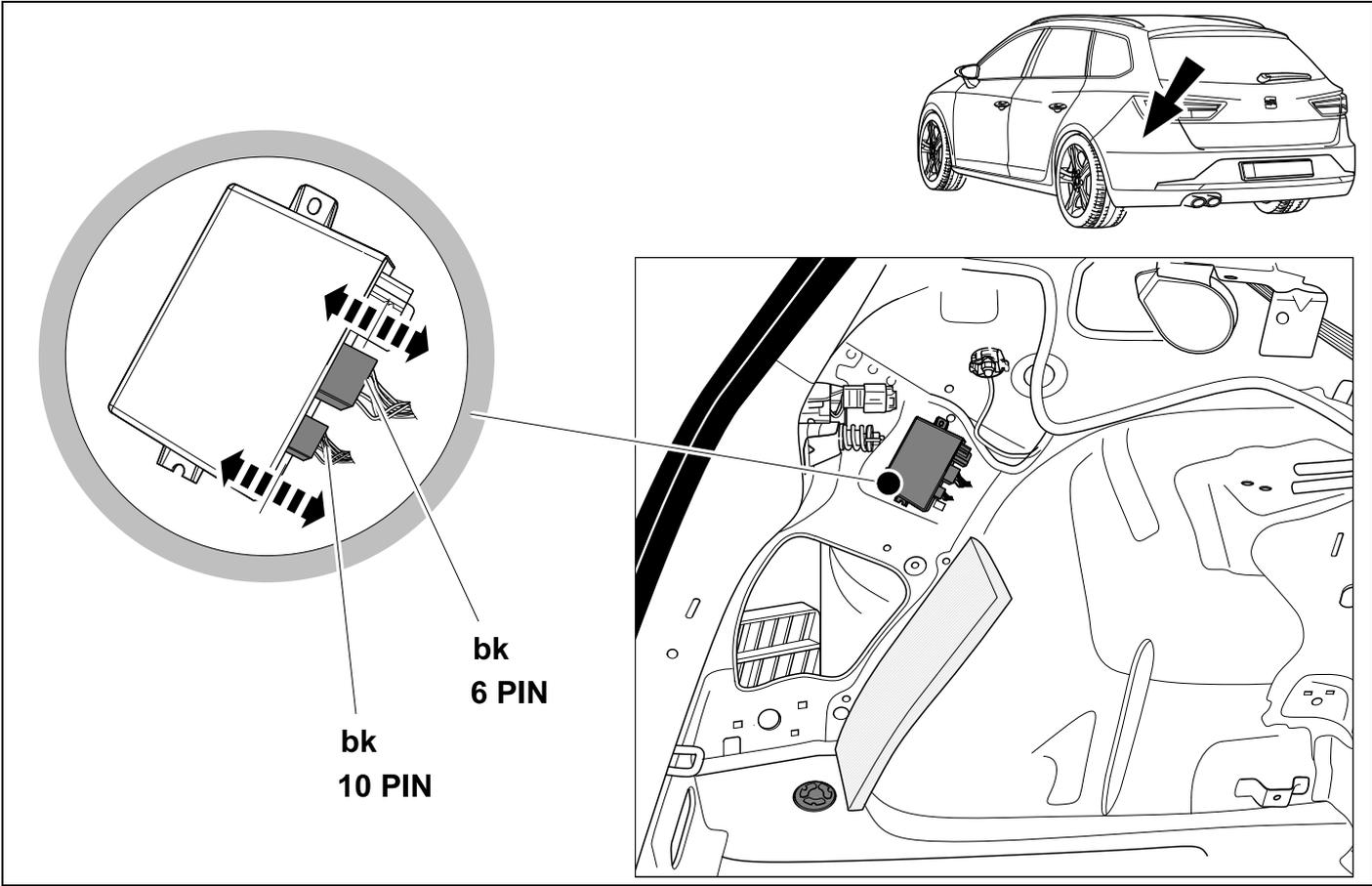

34



11

OPTION 5

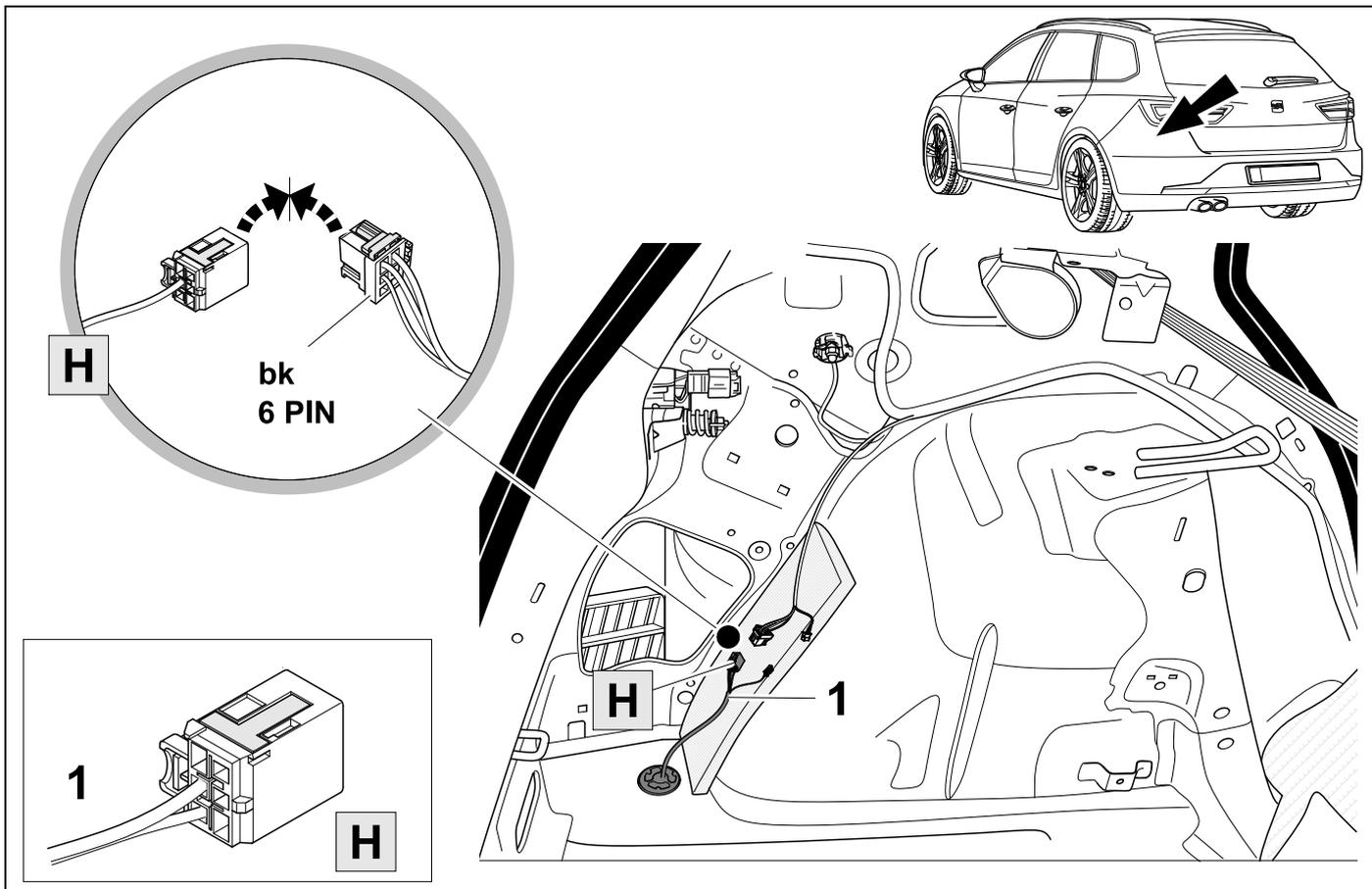

35



11

OPTION 5

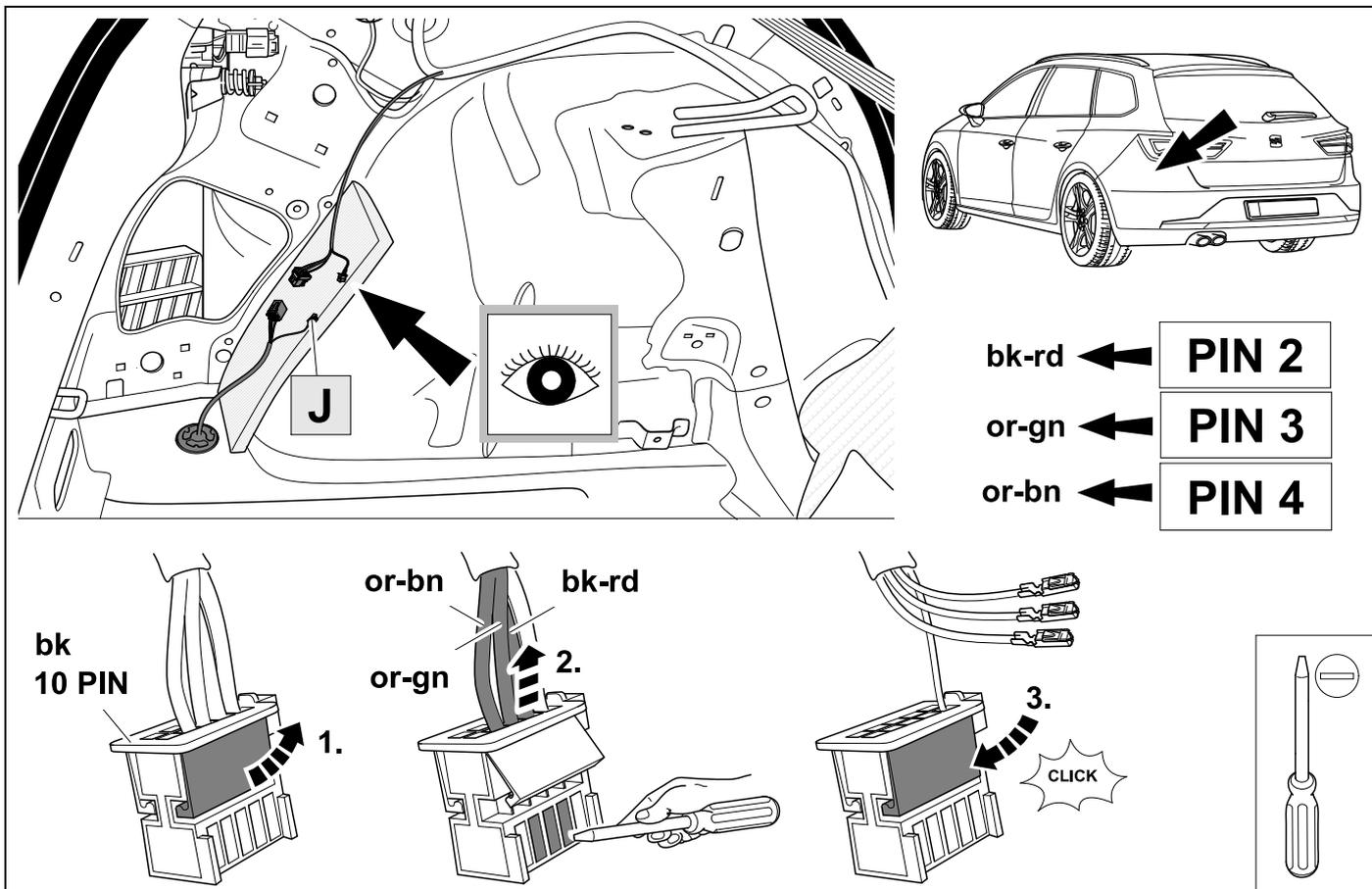

36



11

OPTION 5

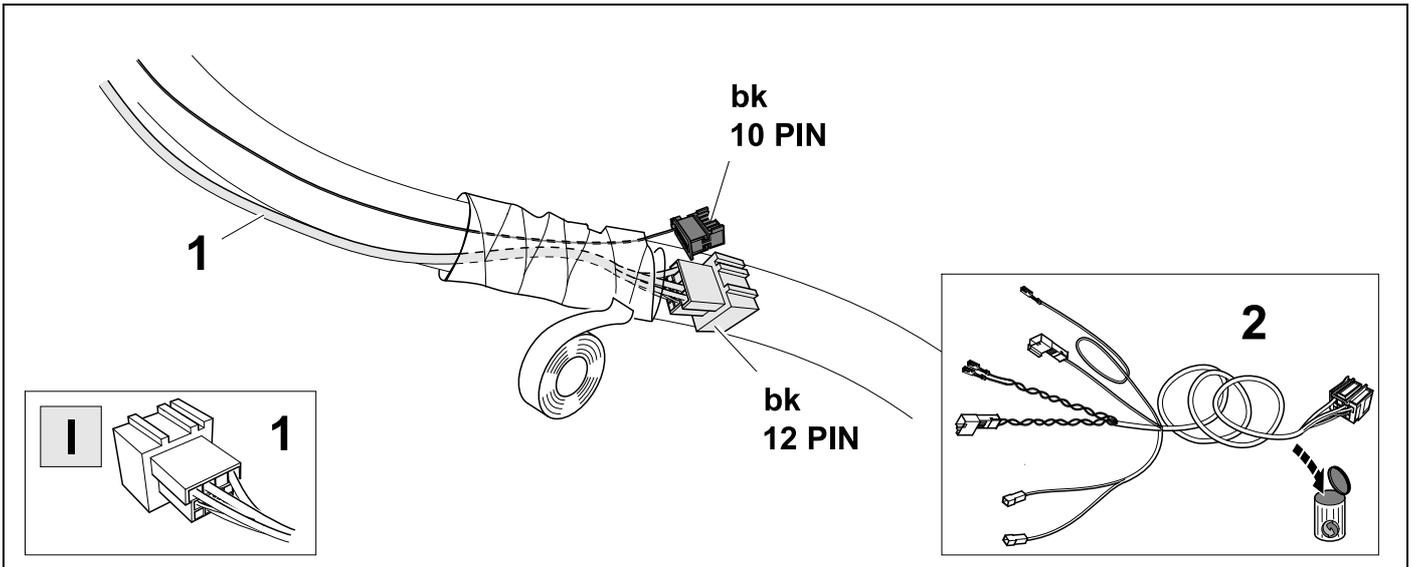

37



11

OPTION 5

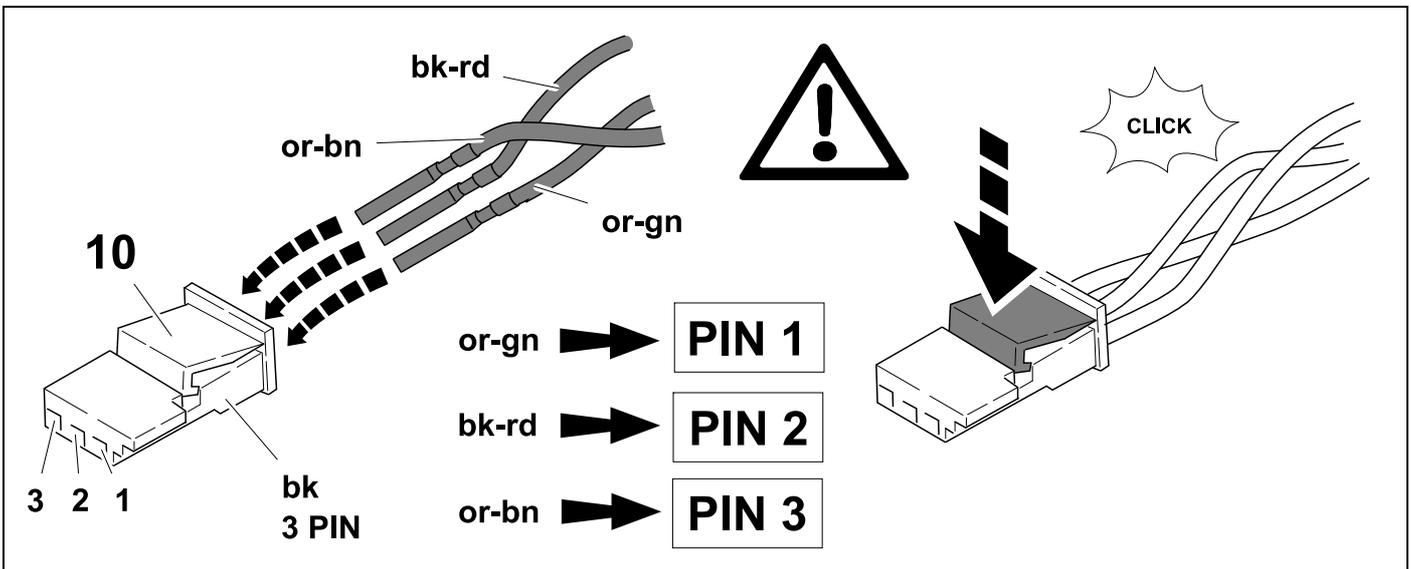

38

OPTION 5

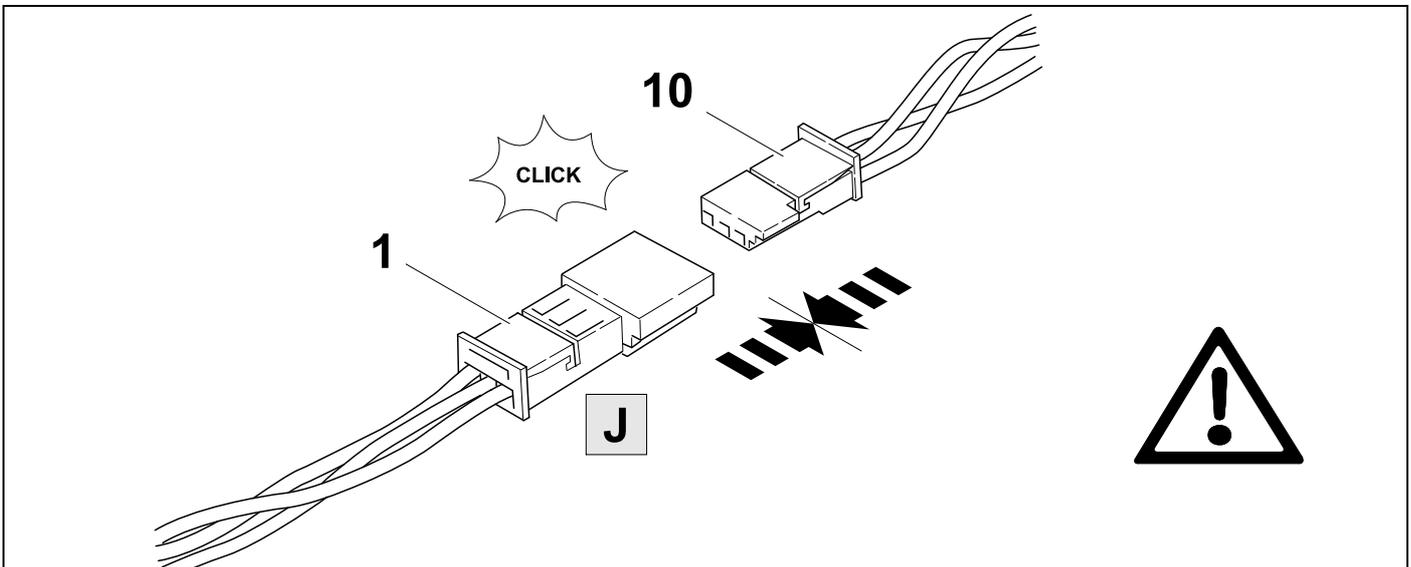

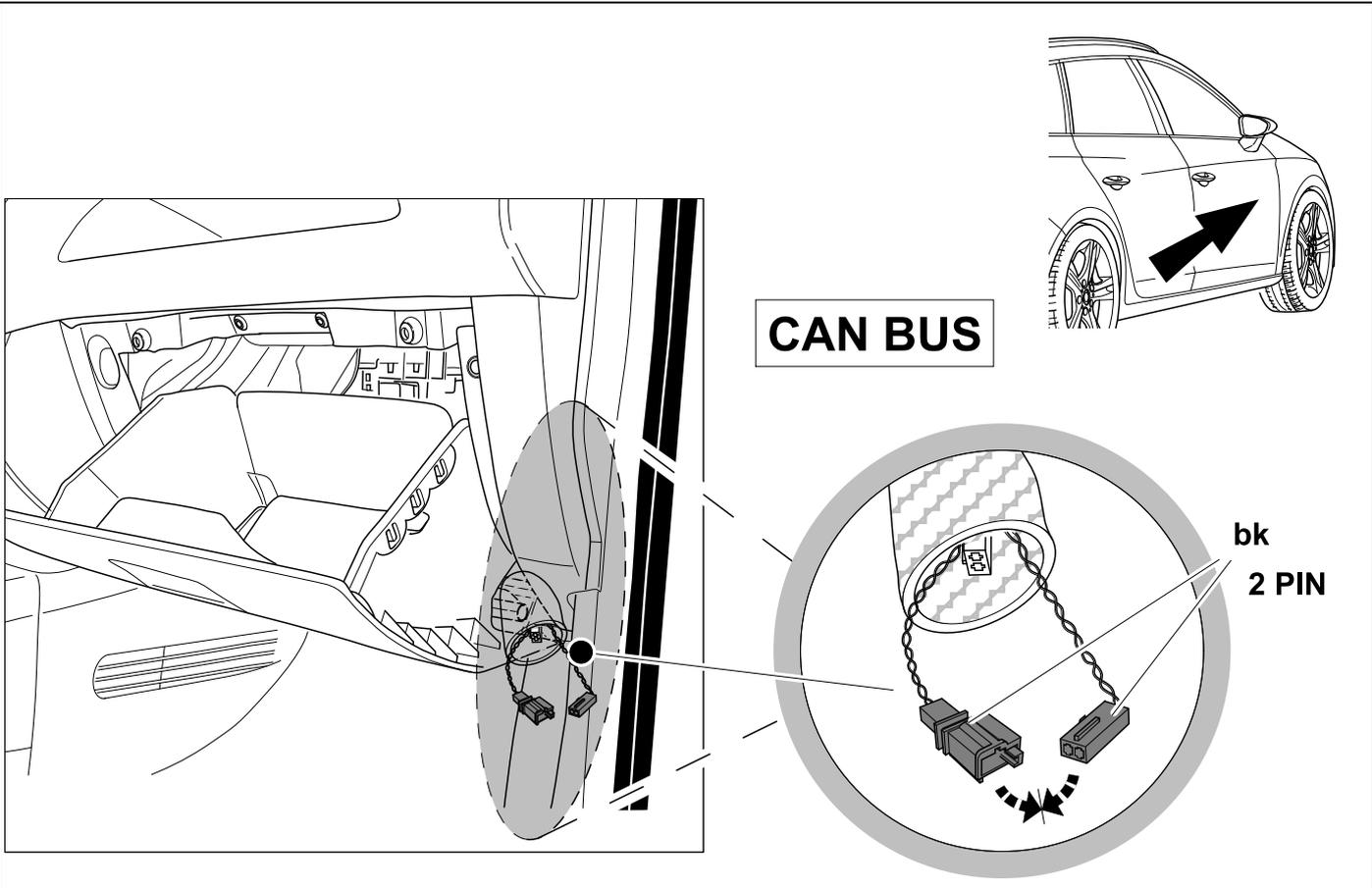

40 OPTIONAL

764159

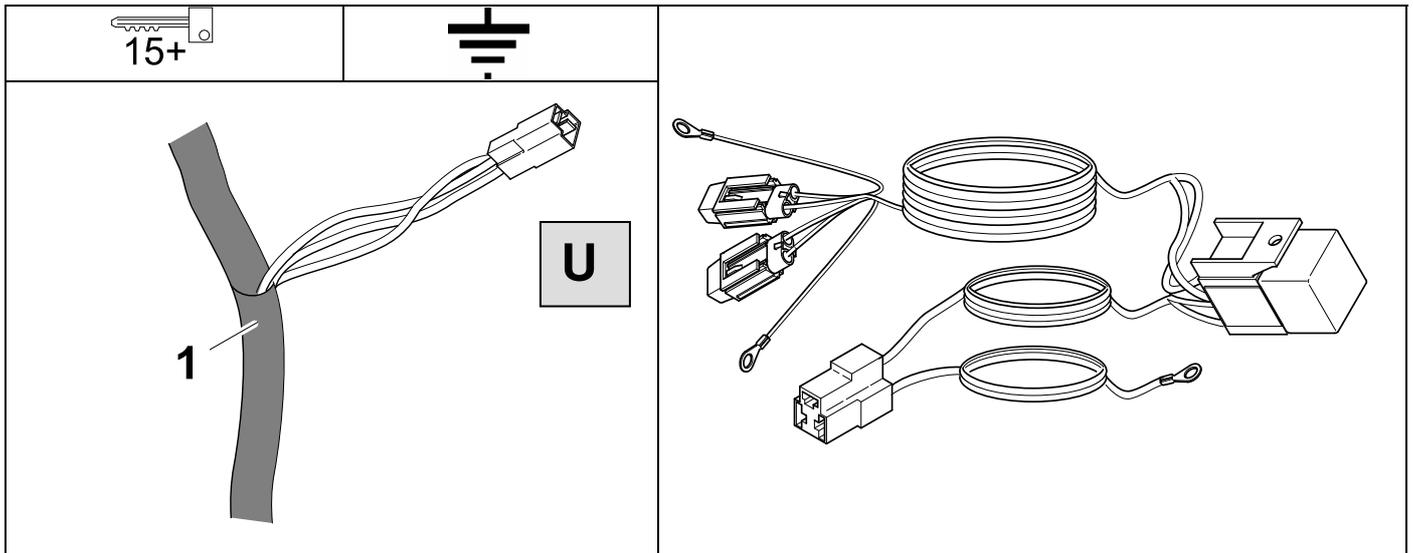

41

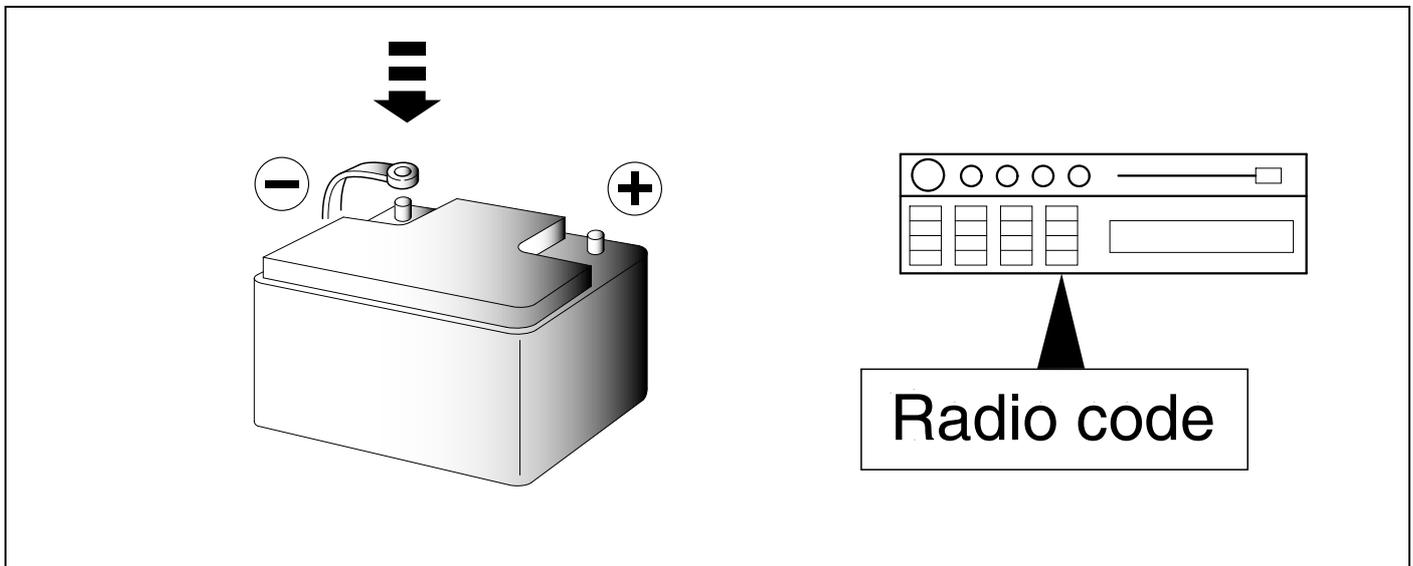

42 CHECK

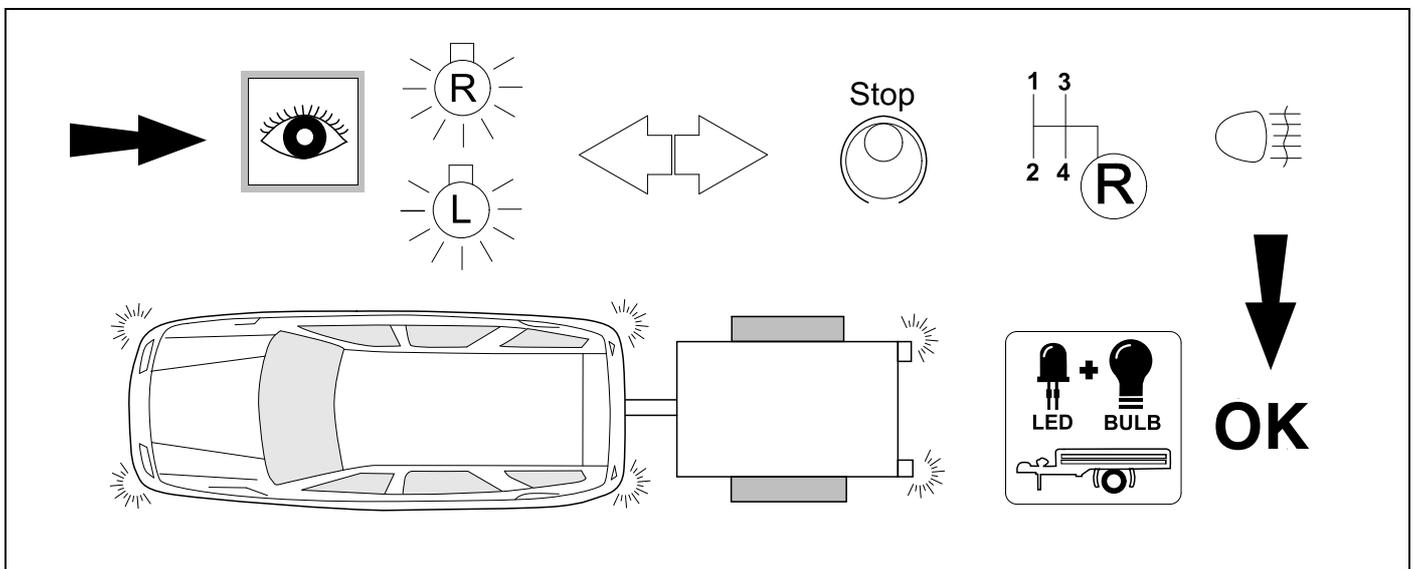

43 OPTIONAL

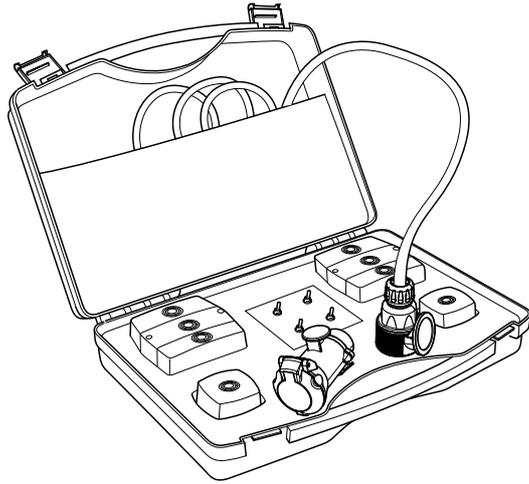

**Trailer Simulator
for 7p and 13p
sockets**

765069

44 CHECK

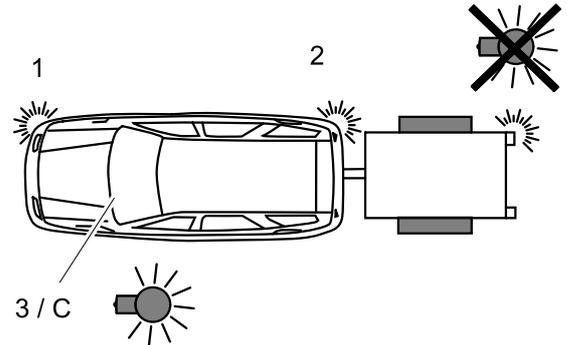
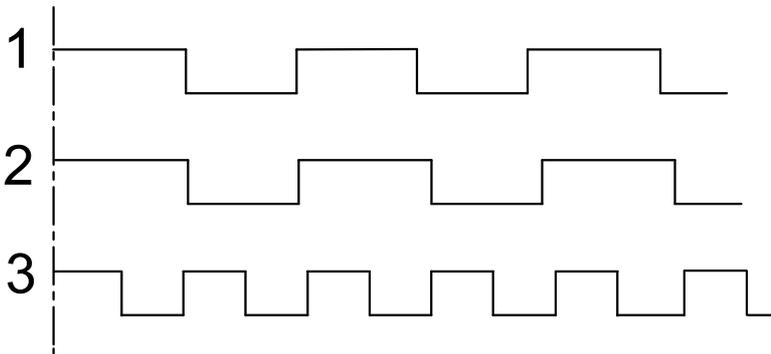

45 Information Service



18

- 19

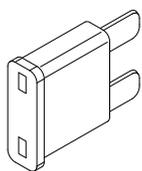

20 A

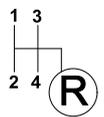
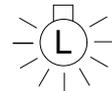
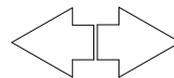
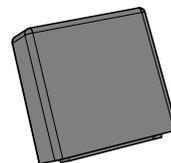
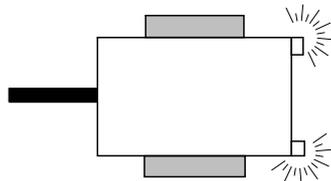

Stop

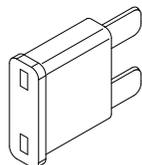
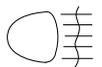
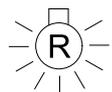

15 A

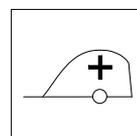
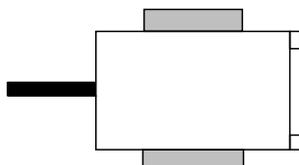

**Need help programming this wiringkit?**

If possible, we provide tips in our manuals on how the vehicle can be coded. It is always possible that more or different coding steps are required for your specific vehicle. That is why we recommend the use of Jifeline.

Jifeline codes your vehicle online with the most up to date knowledge.

**Fahrzeuge mit PR: 1D8
Vorbereitung sind
bereits Codiert.**

**Vehicles with PR: 1D8
preparation already
coded.**

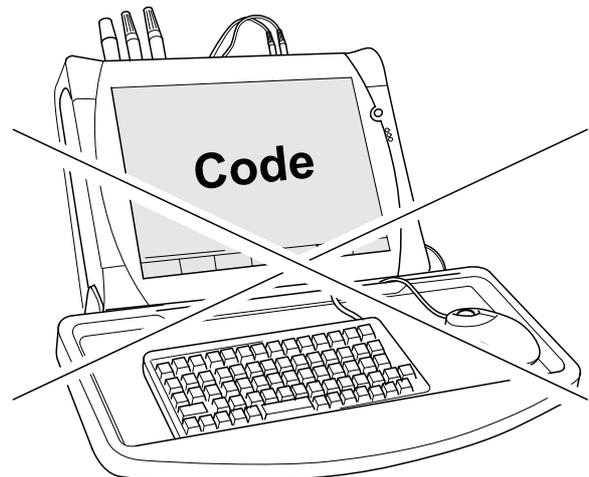

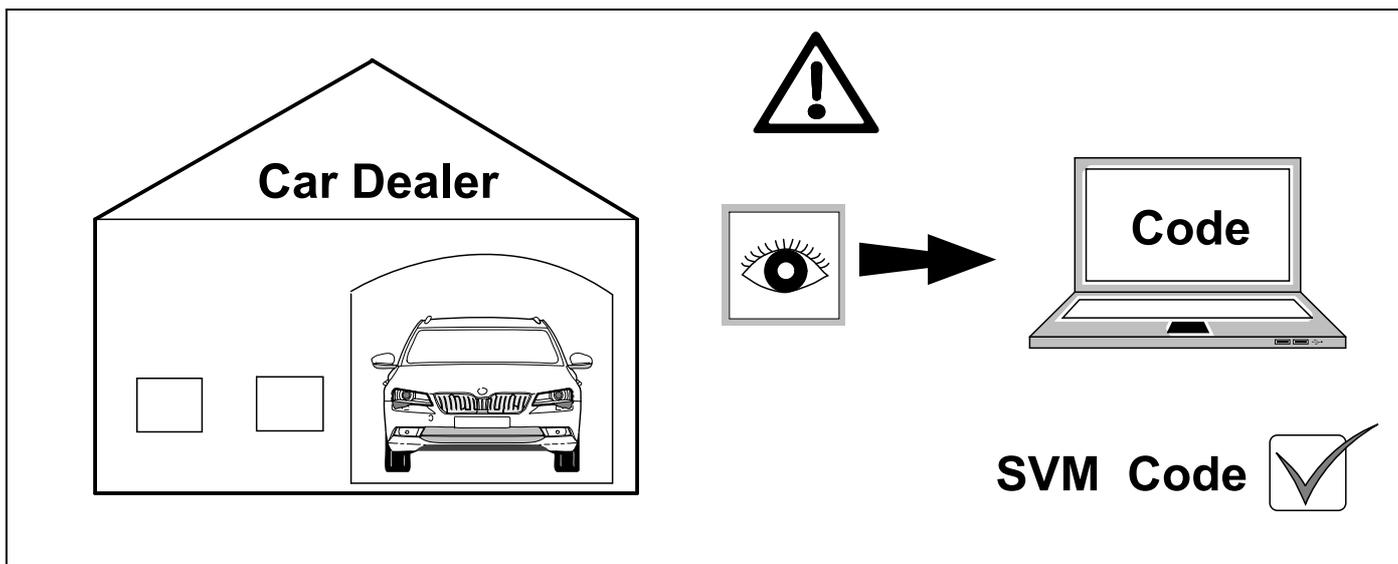
**D**

Nach Verbau des Elektro-Umrüstsatzes muss eine Online-Codierung bzw. Rückdokumentation mittels ODIS wie folgt durchgeführt werden:

- ODIS- Diagnosetester starten
- Funktion „Diagnose“ starten
- „Sonderfunktionen“ auswählen
- „SW anpassen“ auswählen
- Mit „Prüfung durchführen“ bestätigen
- Auswählen Software Aktualisierung über Massnahmencode
- SVM- Code im Eingabefenster eintragen und bestätigen
Code: DA69AHV , DA69AHV123
- Anweisungen des Diagnosetesters befolgen

GB

After fitting the electric installation kit, an online coding or a documentation update must be performed using ODIS as follows:

- Start ODIS diagnostic System
- Start “Diagnostic” function
- Select “Special functions”
- Select “Adapt SW”
- Confirm with “Perform test”
- Select “Perform upgrading and retrofitting solutions”
- Enter and confirm SVM- Code in the input window
Code: DA69AHV , DA69AHV123
- Follow the instructions of diagnosis system

F

Après avoir installé le faisceau d'attelage, il est nécessaire d'effectuer un codage en ligne ou une rétro-documentation à l'aide d'ODIS, comme suit :

- Démarrer le système de diagnostic ODIS
- Activer la fonction «Diagnostic»
- Sélectionner «Fonctions Spéciales»
- Sélectionner «Adapter le logiciel»
- Confirmer «Effectuer le contrôle»
- Sélectionner «Rééquipements et post équipements »
- Entrer et confirmer le code SVM dans la fenêtre de saisie
Code: DA69AHV , DA69AHV123
- Suivre les instructions du système de diagnostic

I

Dopo aver installato il kit elettrico, è necessario effettuare la codifica online utilizzando il sistema diagnostico ODIS come segue:

- Avviare il sistema diagnostico ODIS
- Avviare la funzione “Diagnostica”
- Selezionare “Funzioni Speciali”
- Selezionare “Adeguamento SW”
- Confermare “Esegui Test”
- Selezionare “Esegui aggiornamento /adeguamento”
- Inserire e confermare il codice SVM nella finestra di input
Code: DA69AHV , DA69AHV123
- Seguire le istruzioni del sistema diagnostico

E

Tras la instalación del kit eléctrico, es necesario efectuar una codificación online o una documentación retrospectiva a través de ODIS de la manera siguiente:

- Iniciar el sistema de diagnostico ODIS
- Iniciar la función “Diagnóstico”
- Seleccionar “Funciones Especiales”
- Seleccionar “Adaptar Software”
- Confirmar “Efectuar Comprobación”
- Seleccionar “Realizar adaptación y reequipamiento”
- Entrar y confirmar el código SVM en la ventana de entradas
Code: DA69AHV , DA69AHV123
- Seguir las instrucciones del sistema de diagnostico

NL

Na installatie van de kabelset dient online codering plaats te vinden of een update in de documentatie middels ODIS systeem volgens de methode:

- Start ODIS diagnose Systeem
- Start “Diagnostic” functie
- Selecteer “Special functions”
- Selecteer “Adapt SW”
- Bevestig met “Perform test”
- Selecteer “Perform upgrading and retrofitting solutions”
- Enter en bevestig SVM- Code in het invoer veld
Code: DA69AHV , DA69AHV123
- Volg de instructies van het diagnose systeem

49 OPTIONAL

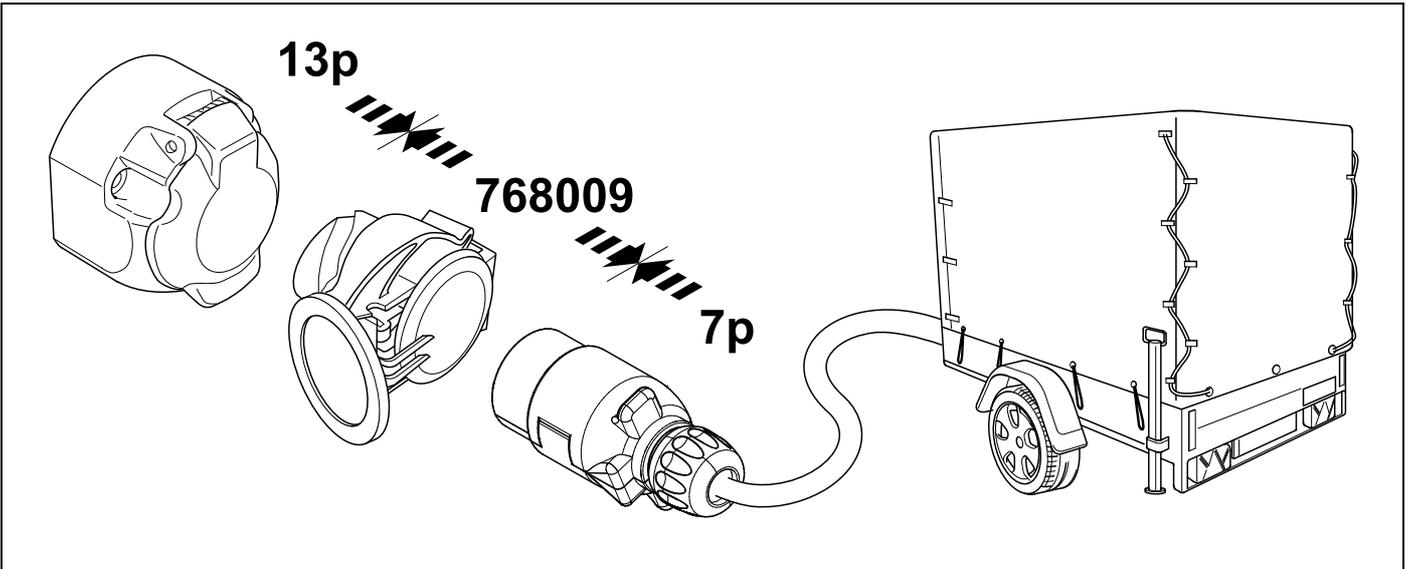

50 PLEASE NOTICE

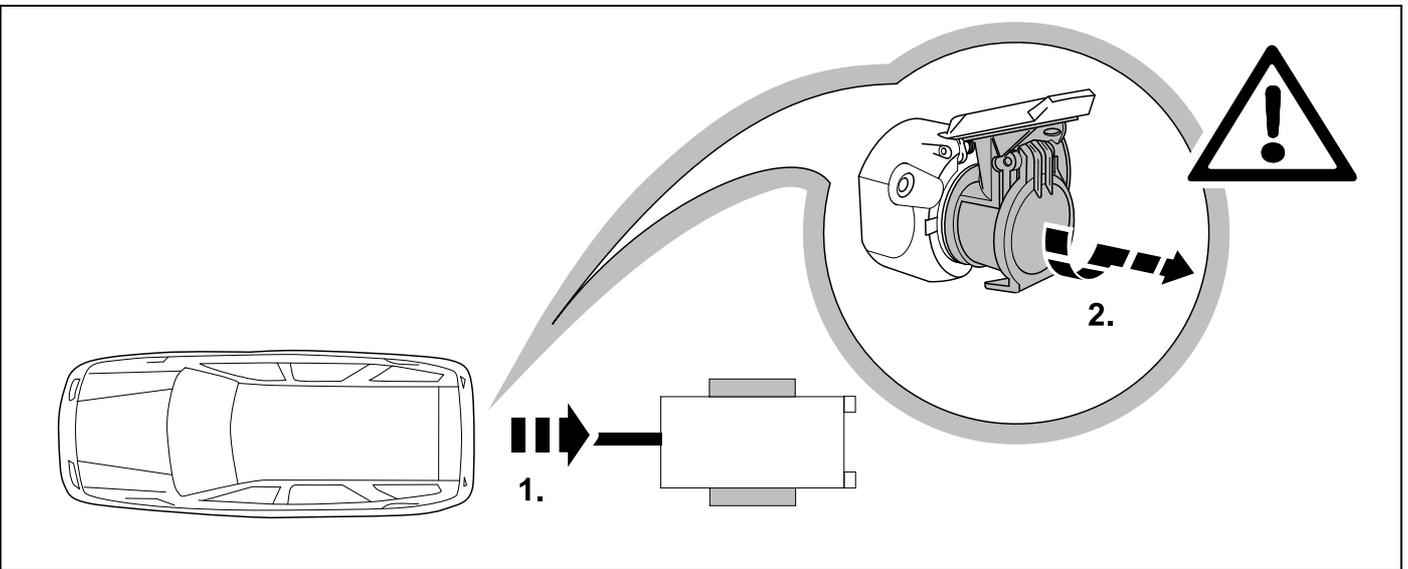

51

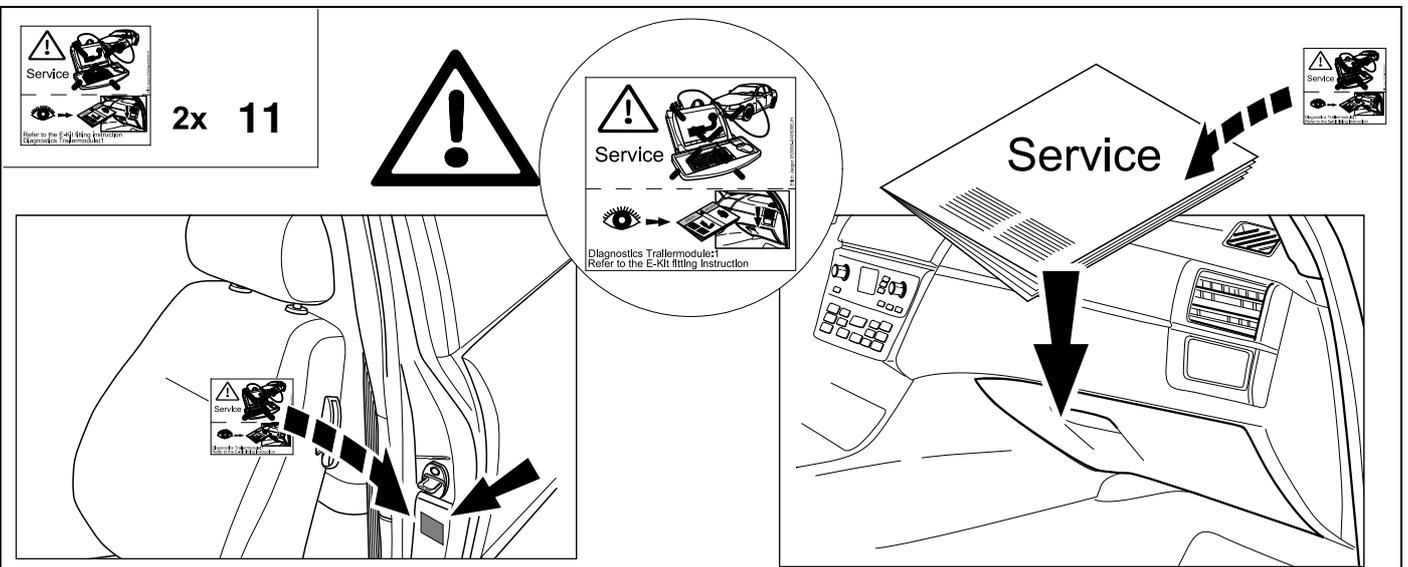

Status LED für Eigendiagnose

Status LED for self-diagnosis

Operation support

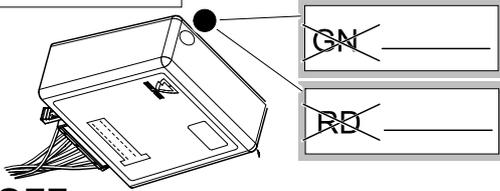

No CAN-Data =



Standby / Sleepmode



Ignition OFF

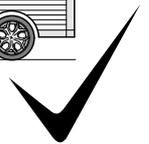
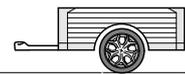
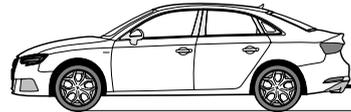
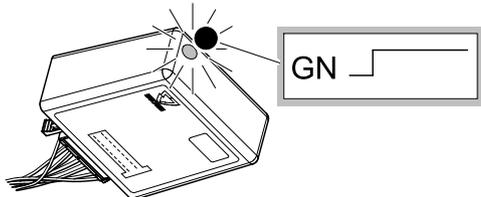

Ignition ON

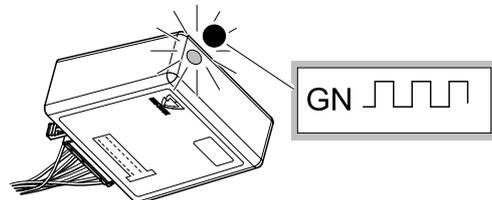

Ignition ON

Failure support

CAN-Data Wire



1x max. 5 min.

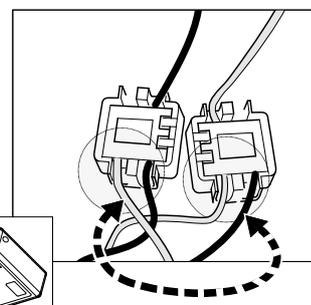
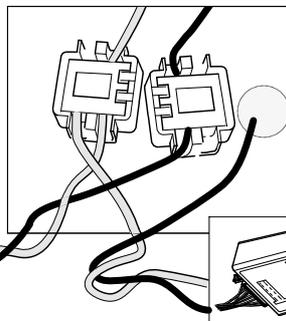
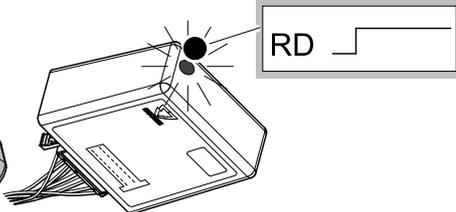

Ignition ON

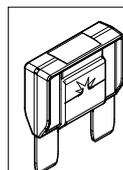
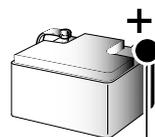
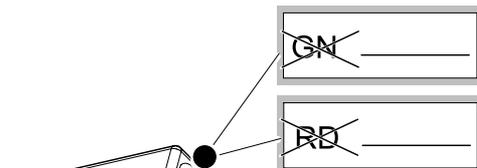
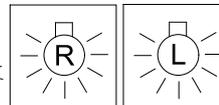

+30 PIN 17 oder / or

31 PIN 1

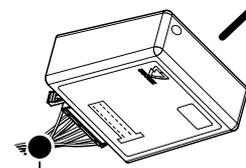
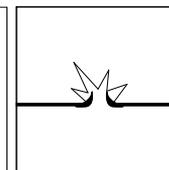

Ignition ON

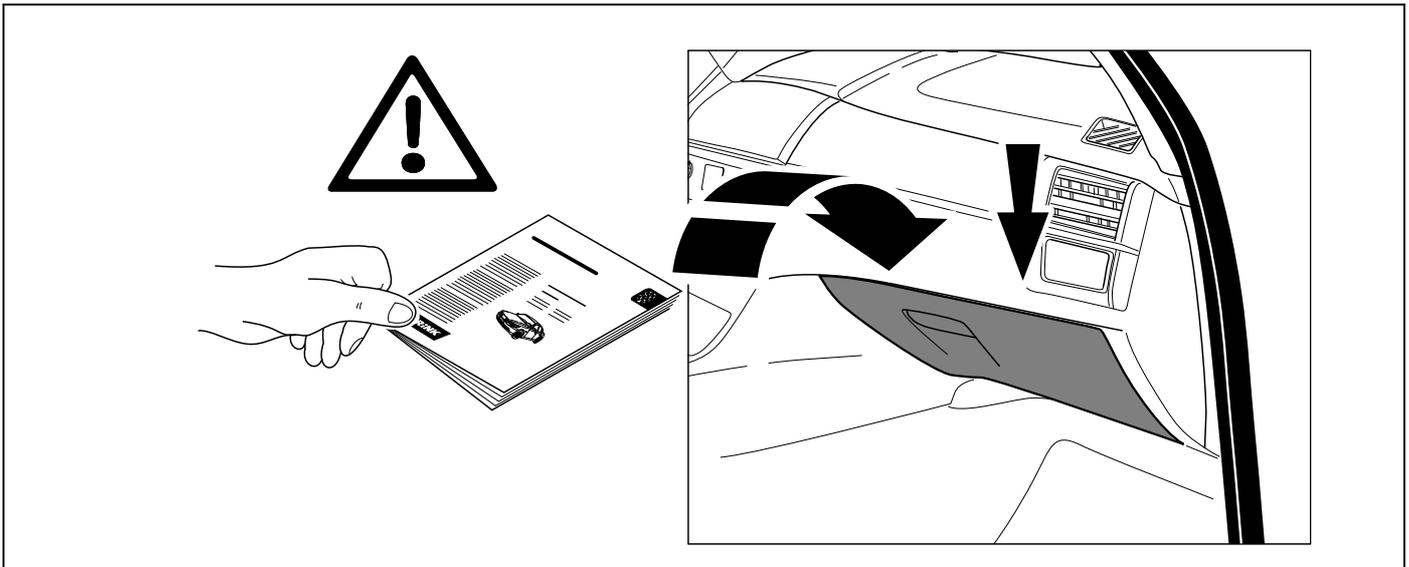

D	Änderungen bezüglich Konstruktion, Ausstattung Farbe sowie Irrtum vorbehalten. Angaben und Abbildungen unverbindlich	PL	Zastrzega się prawo do zmian dot. konstrukcji, wykończenia, kolorystyki oraz pomyłek. Dane i ilustracje niewiążące.
GB	Subject to change in terms of construction, equipment and colour, and may contain errors. The information and illustrations are non-binding.	TR	Tasarım, donanım ve renk bakımından değişiklik yapma hakkı ve hata ve eksiklik mahfuzdur. Veriler ve resimler bağlayıcı değildir.
F	Sous réserve de modifications de la construction, de équipement, de la couleur et sous réserve d'erreurs. Les indications et les illustrations sont sans engagement.	H	A szerkezet, a kivitelt és a szín változtatása, valamint a változások joga fenntartva. Az adatok és az ábrák nem kötelező érvényűek.
NL	Wijzigingen met betrekking tot constructie, uitvoering en kleur evenals vergissingen voorbehouden. Gegevens en afbeeldingen niet bindend.	HR	Pravo promjena u svezi konstrukcije, opreme, boje kao i zabune oridžavamo. Podaci i ilustracije su neobavezne.
DK	Ændringer med hensyn til konstruktion, udstyr, farver samt fejl forbeholdes. Oplysninger og illustrationer er uforpligtende.	BUL	Запазени права по отношение на конструкцията, обзавеждането, цвета и грешки. Данните и изображенията не са обвързващи.
N	Ændringer angående konstruksjon, utstyr, farge og feiltagelse forbeholdes. Oplysninger og illustrasjoner uforbindtlig.	RO	Ne rezervăm dreptul unor modificări ale construcției, dotării, culorii și dreptul la erori Datele indicate și imaginile sunt orientative.
S	Med reservation för ändringar vad det gäller konstruktion, utrustning, färg samt för misstag. Uppgifterna och bilderna är inte bindande.	RU	Права на внесение изменений относительно конструкции, оснащения, окраски, а также на ошибки сохраняются. Данные и иллюстрации имеют примерный характер.
FIN	Pidätämme oikeuden rakennetta, varustusta, väriä koskeviin sekä erehdyksestä johtuviin muutoksiin. Tiedot ja kuvat eivät ole sitovia.	LT	Pasilieikama konstrukcijos, įrangos bei reikmenų, spalvos pakeitimų ir klaidų teisė. Duomenys ir iliustracijos neįpareigojantys.
I	Con riserva di modifiche relative a progettazione, dotazione, colore ed errori. Le indicazioni e figure sono fornite senza impegno.	LV	Tiek paturētas tiesības uz konstrukcijas, iekārtu, krāsu izmaiņām, kā arī kļūdīšanās. Dati un attēli bez saistībām.
E	Reservadas las modificaciones respecto a diseño, equipamiento, color, así como error. Indicaciones y figuras sin compromiso.	EST	Konstruktsiooni, varustuse ja võevi osas muudatused ning eksimine lubatud. Andmed ja joonised on mittesiduvad.
P	Reservamos o direito de alterações relativamente ao desenho, equipamento, cor, bem como de erro. Os dados e as gravuras não implicam compromisso da nossa parte.	SLO	Zadržana pravica do sprememb glede konstrukcije, opreme, barve ter pomote. Podatki in slike so neobvezne.
GR	Διατηρώνουμε κάθε επιφύλαξη ως προς αλλαγές σε σχέση με κατασκευή, εξοπλισμό, διαρρύθμιση, χρωματισμούς και λάθη παραδρομής.	SK	Zmeny, ktoré sa týkajú konštrukcie, vybavenia, farby, ako aj omyly sú vyhradené. Údaje a zobrazenia sú nezáväznú.
CZ	Změny, týkající se konstrukce, vybavení, barvy, jakož i omyly jsou vyhrazeny. Údaje a vyobrazení jsou nezáväznú.		