

Wiringkit

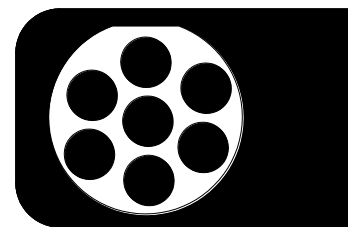

D	Einbauanleitung
GB	Installation instructions
F	Consignes de montage
NL	Montagehandleiding
DK	Montagevejledning
N	Monteringsinstruksjon
S	Installationsanvisning
FIN	Asennusohje
I	Istruzioni per il montaggio
E	Instrucciones de montaje
P	Instruções de montagem
GR	Οδηγίες εγκατάστασης
CZ	Návod k montáži
SLO	Navodilo za vgradnjo
SK	Montážny návod
PL	Instrukcja montażu
TR	Montaj talimatı
H	Beépítési útmutató
HR	Upute o ugradnji
BUL	Инструкция за монтаж
RO	Instrucțiuni de montaj
RU	Инструкция по монтажу и установке
LT	Montavimo informacija
LV	Iemontēšanas pamācība
EST	Paigaldusjuhend

756573 VOLKSWAGEN

- **Passat Limousine** 11/10 >>
- **Passat Variant** 11/10 >>
- **Passat Alltrack** 02/12 >>
- **CC** 01/12 >>
- **Jetta** 01/11 >>

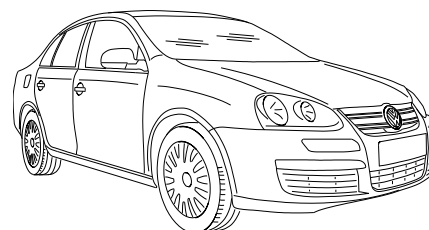
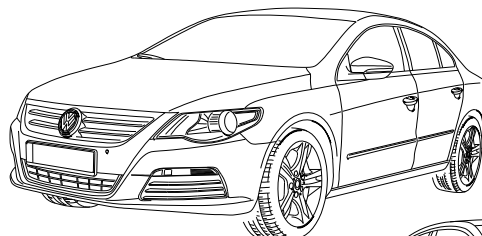
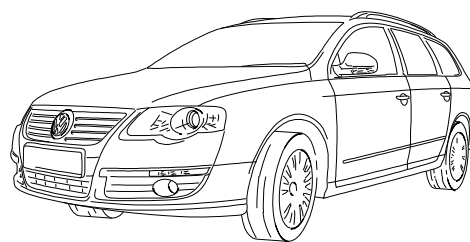
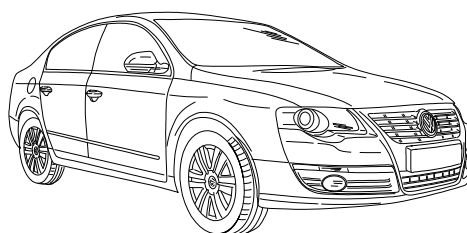

ROUTING

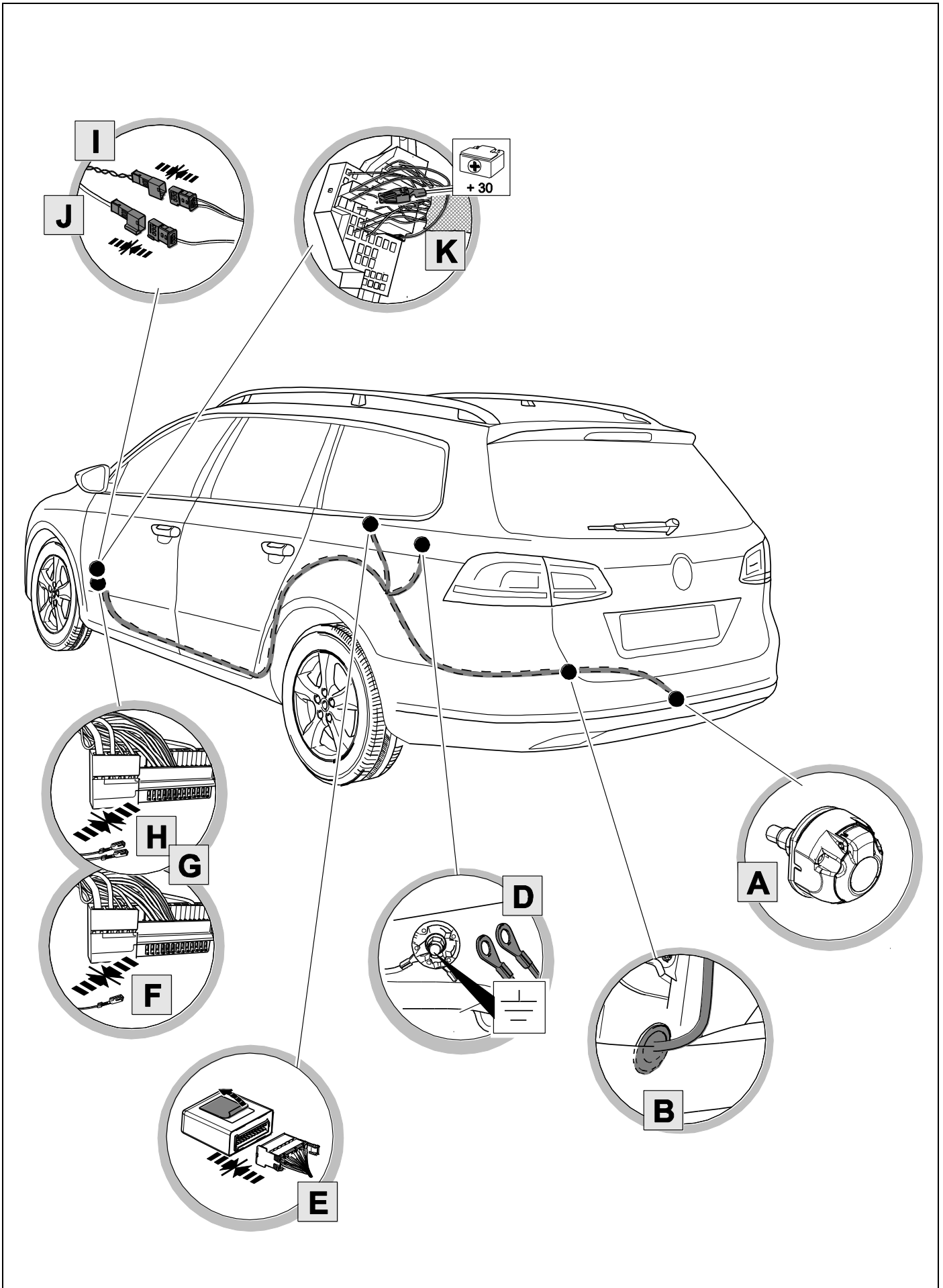

KIT

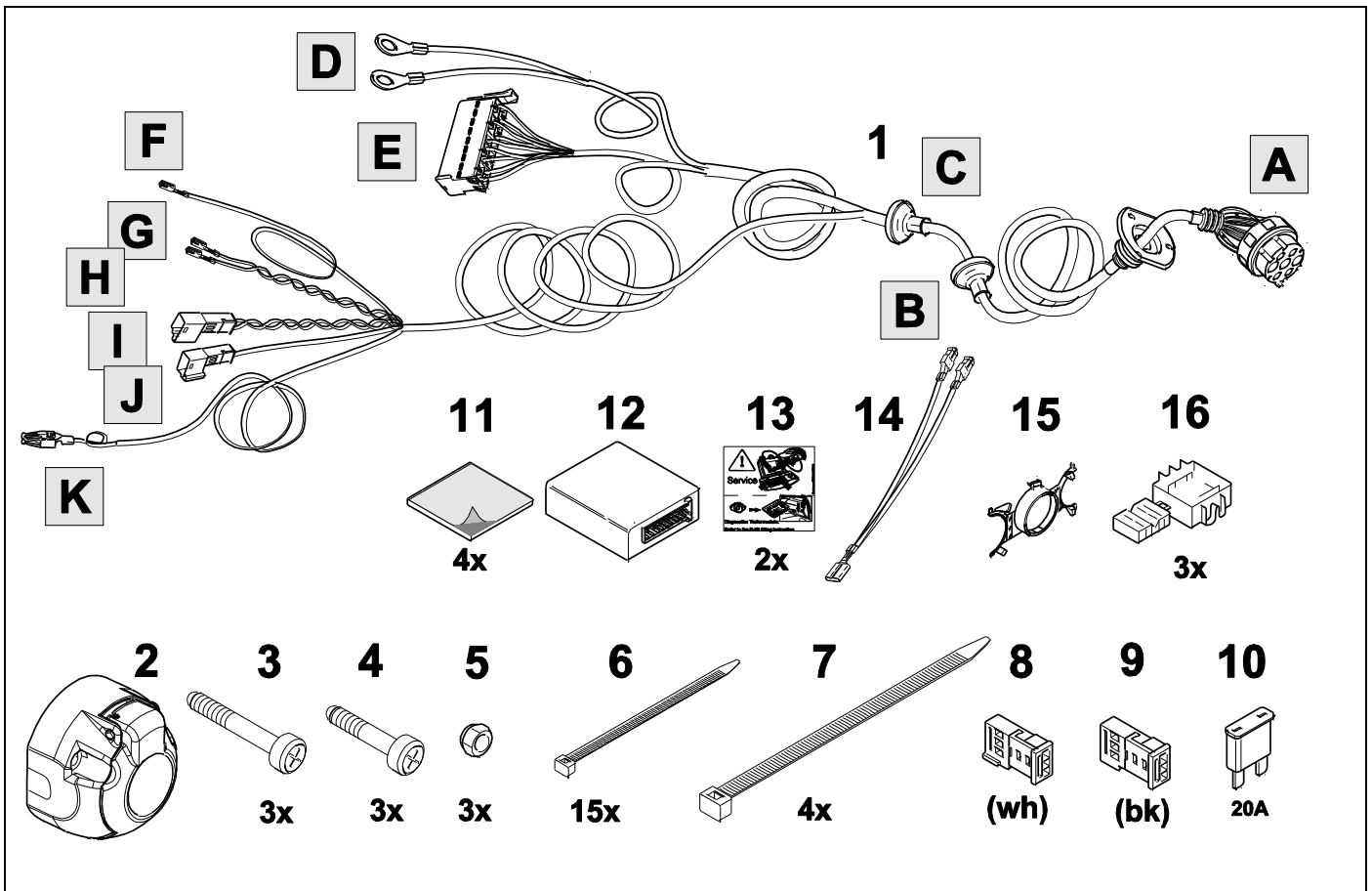

TOOLS

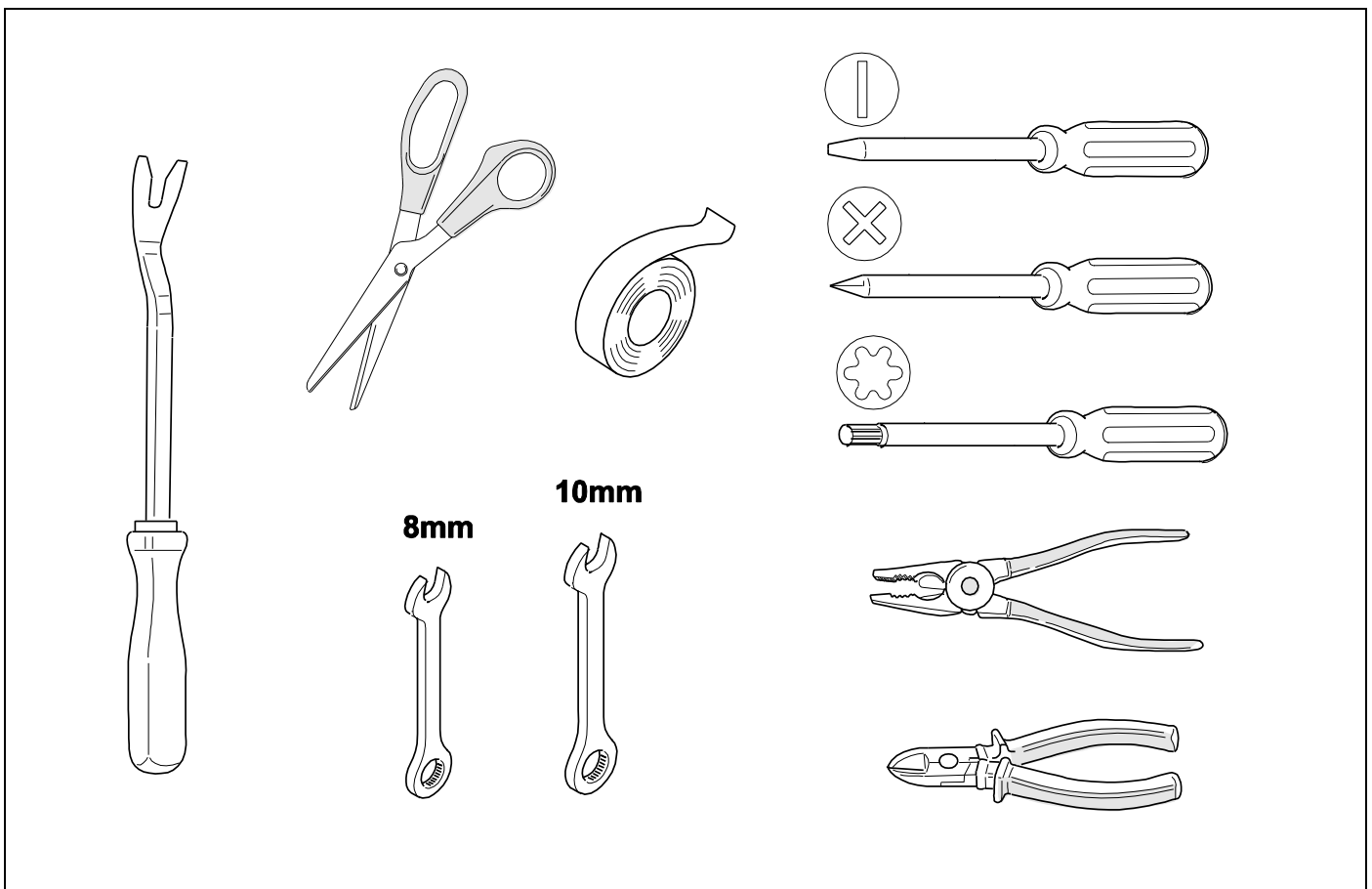

1

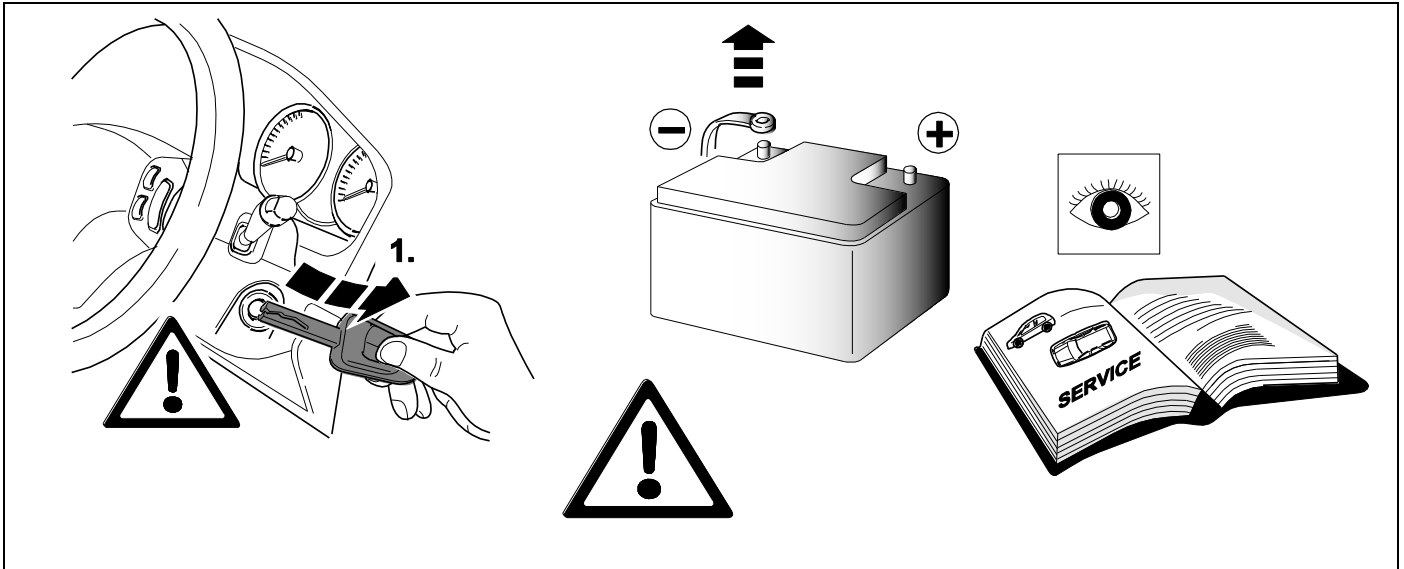

2 REMOVE

Passat Limousine / CC / Jetta

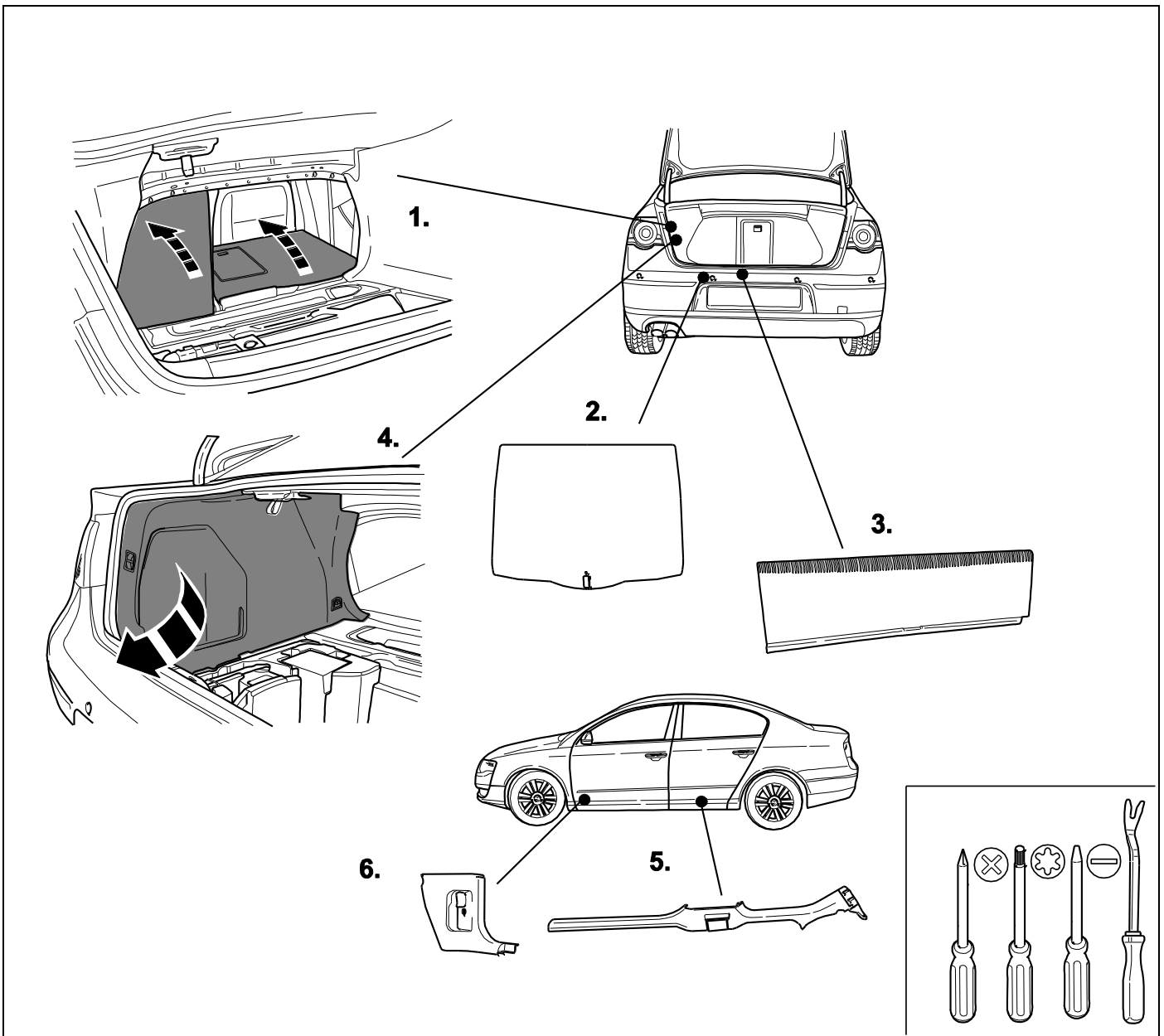

3 REMOVE

Passat Variant = Passat Alltrack

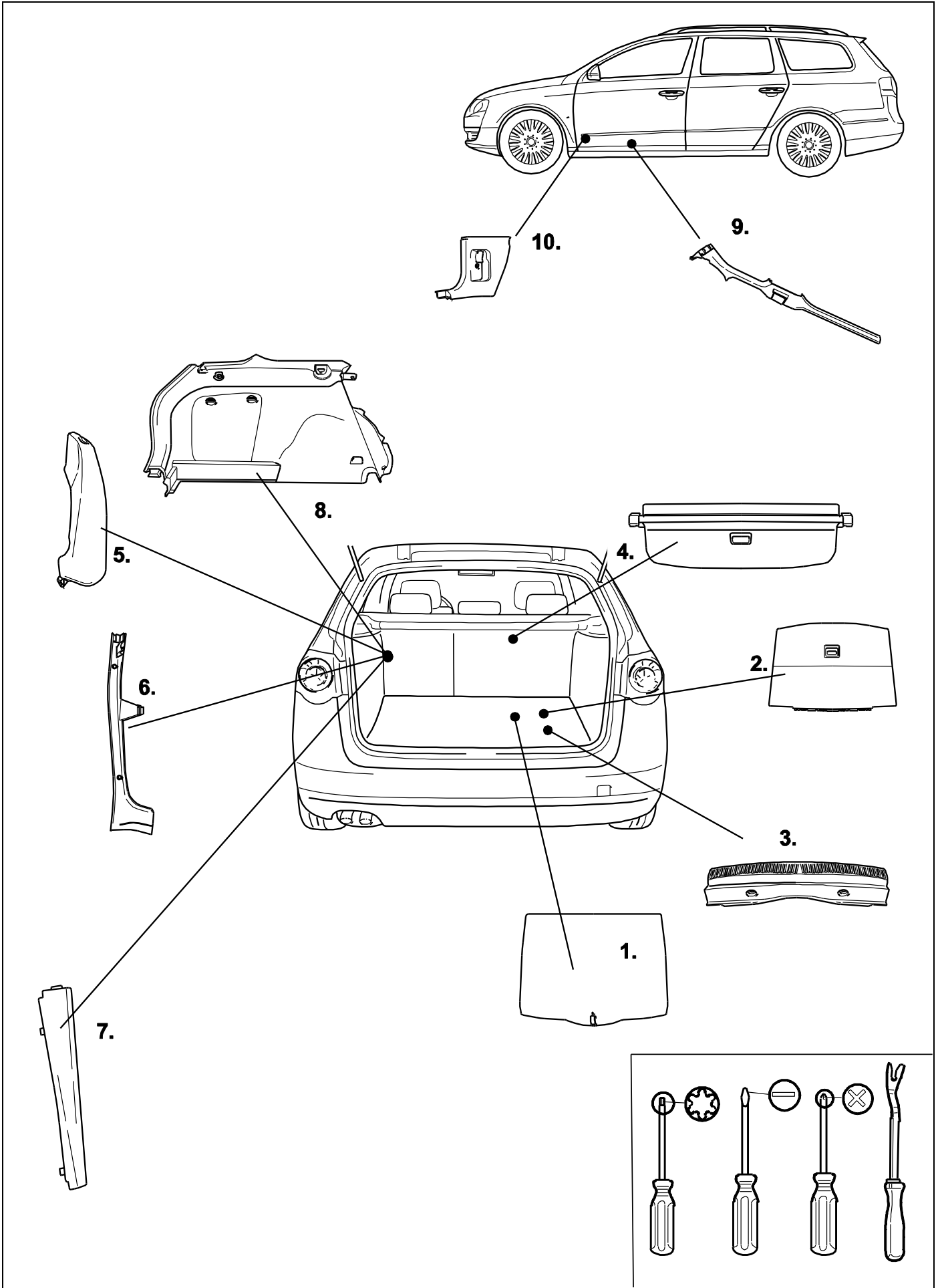

4

Passat Limousine / Jetta

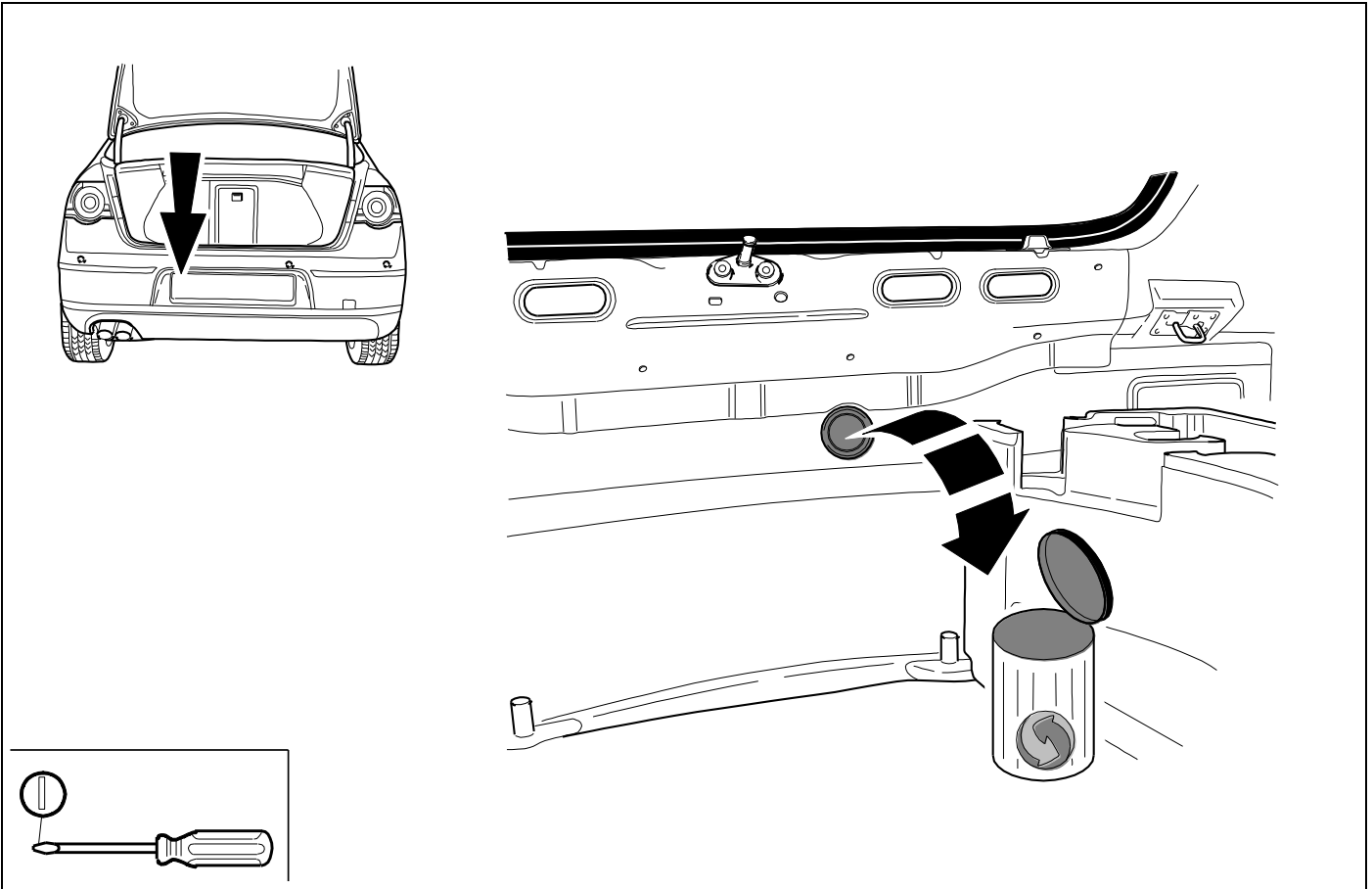

5

Passat Variant / CC

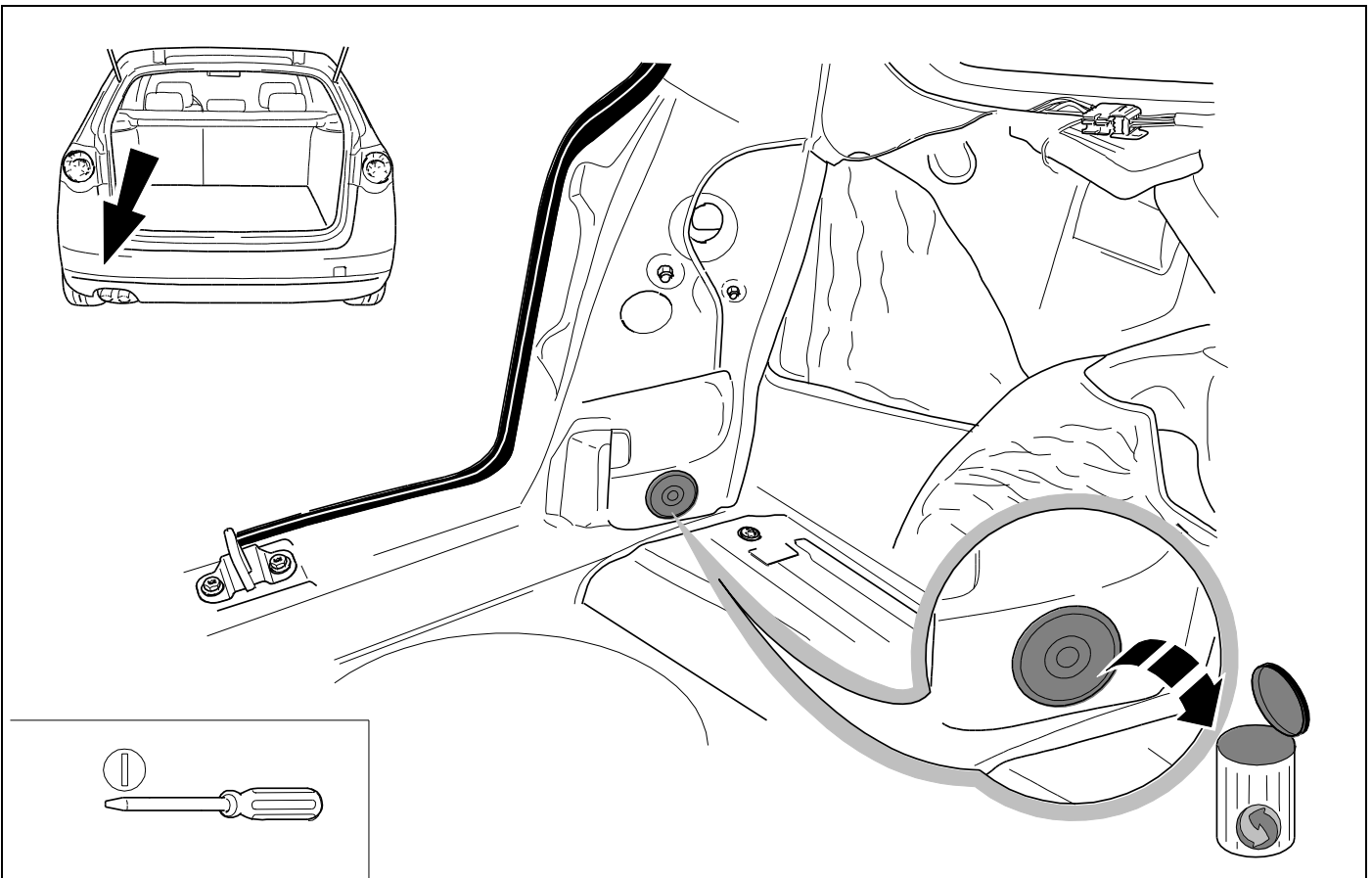

6

Passat Limousine / Jetta

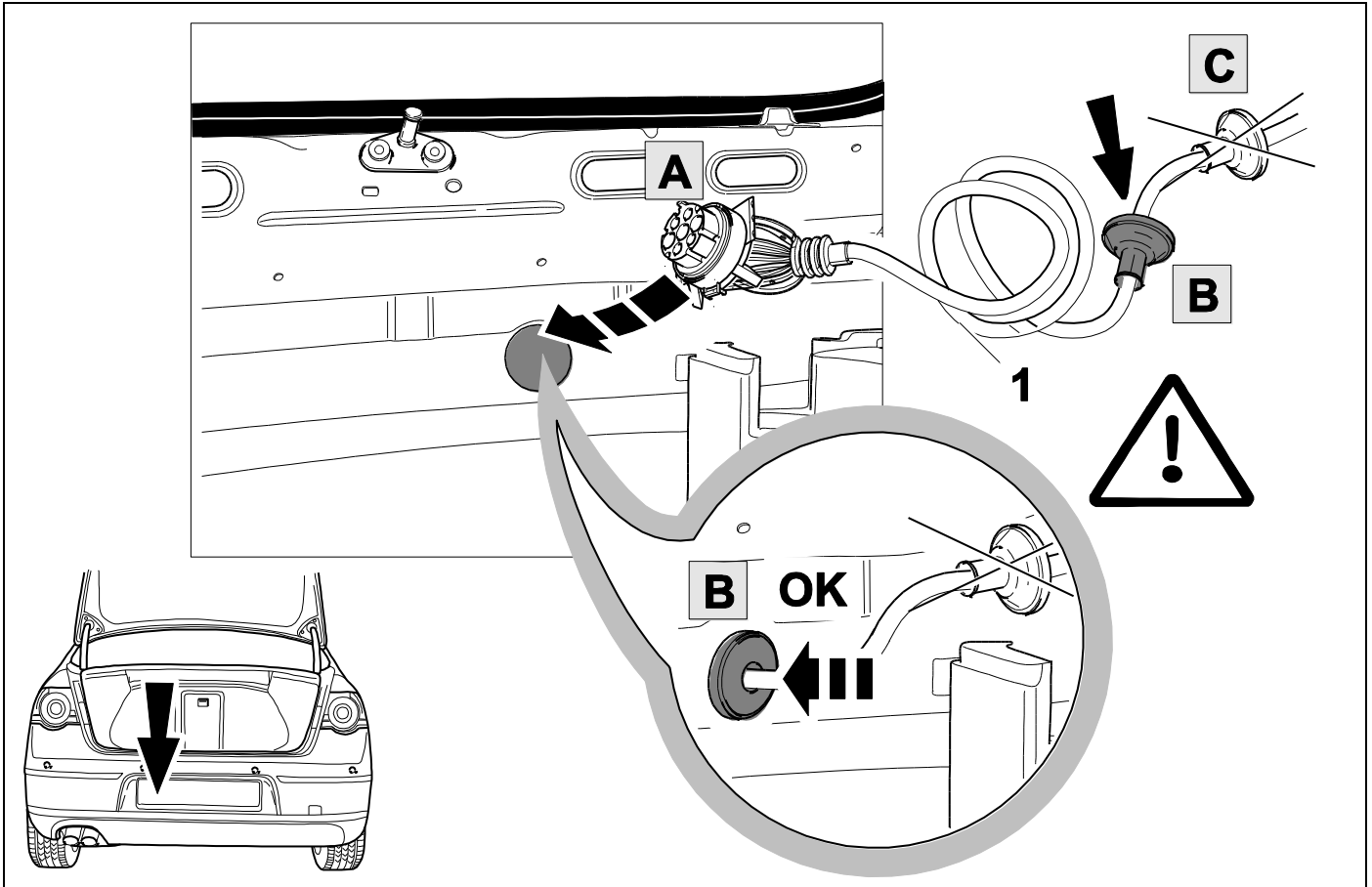

7

Passat Variant / CC

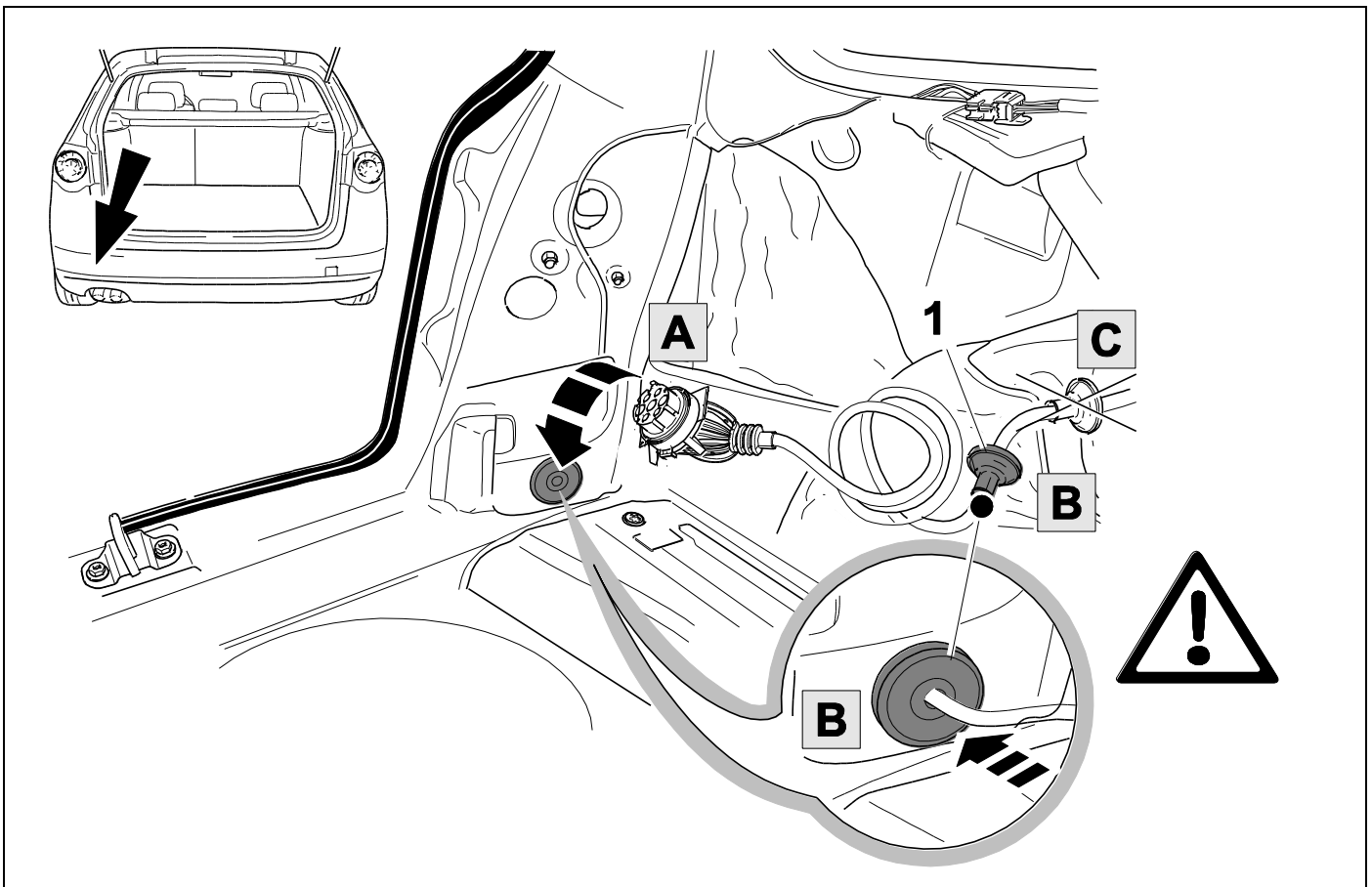

8

Passat Limousine / Jetta

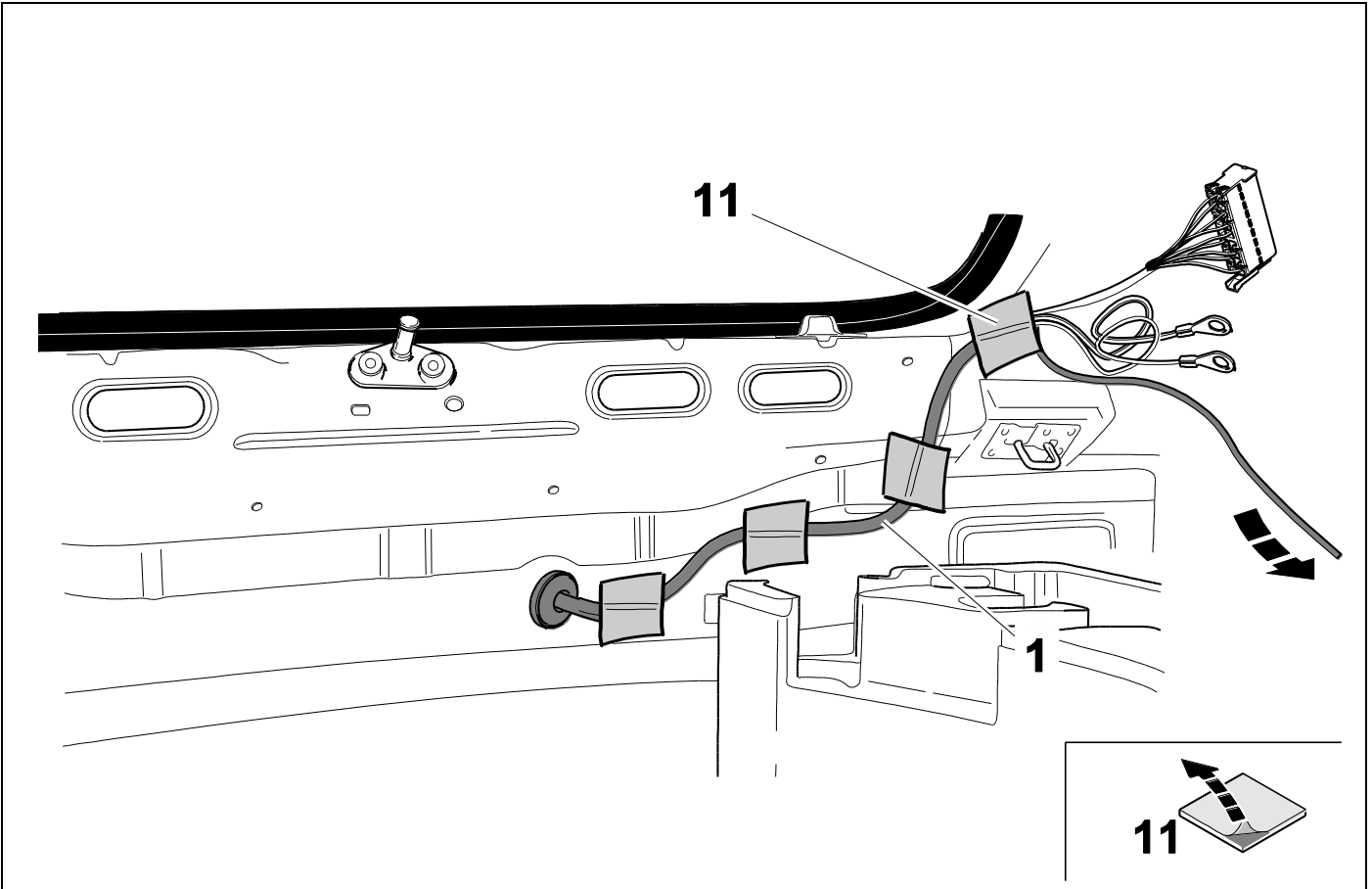

9

Passat Variant

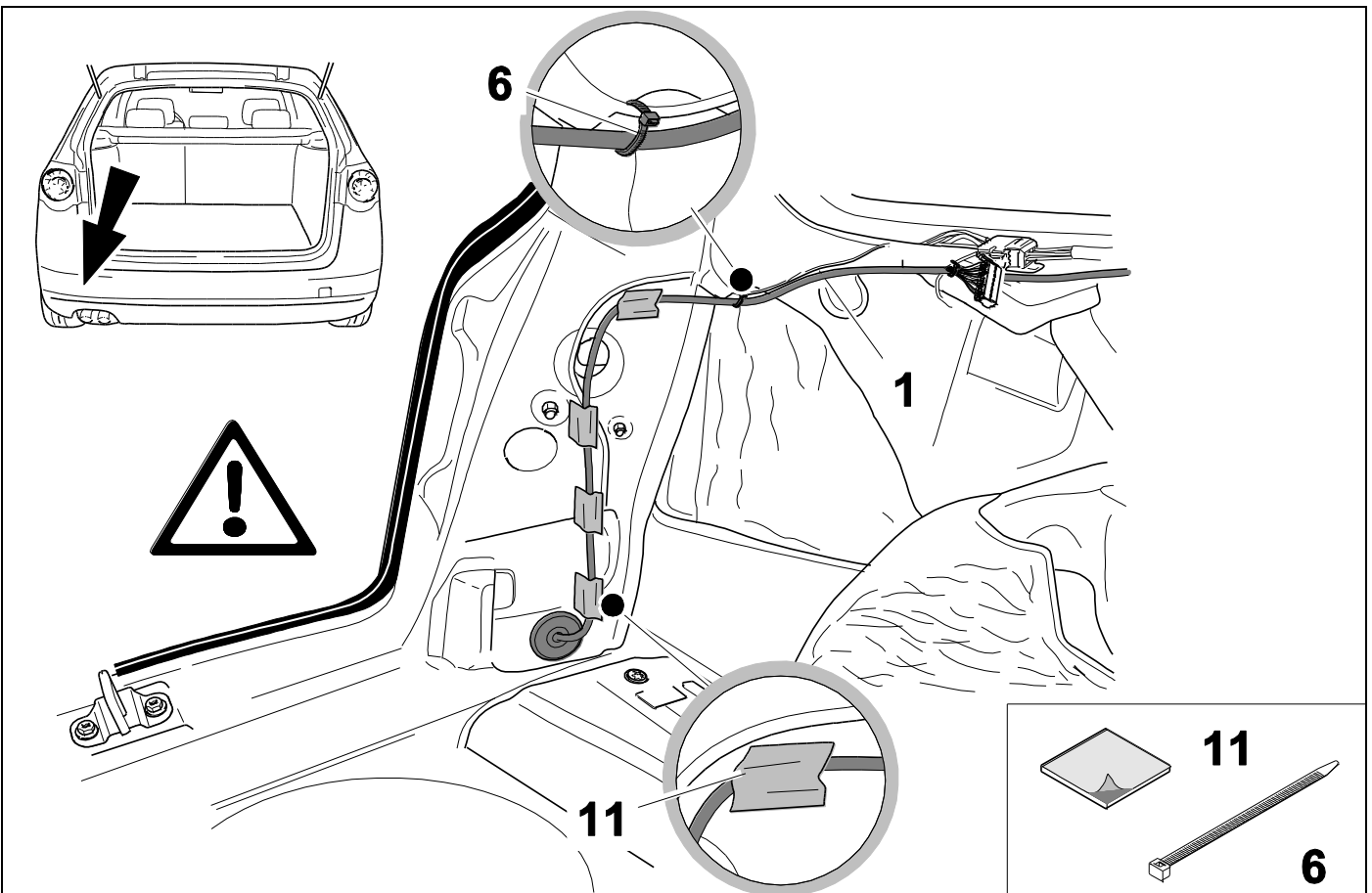

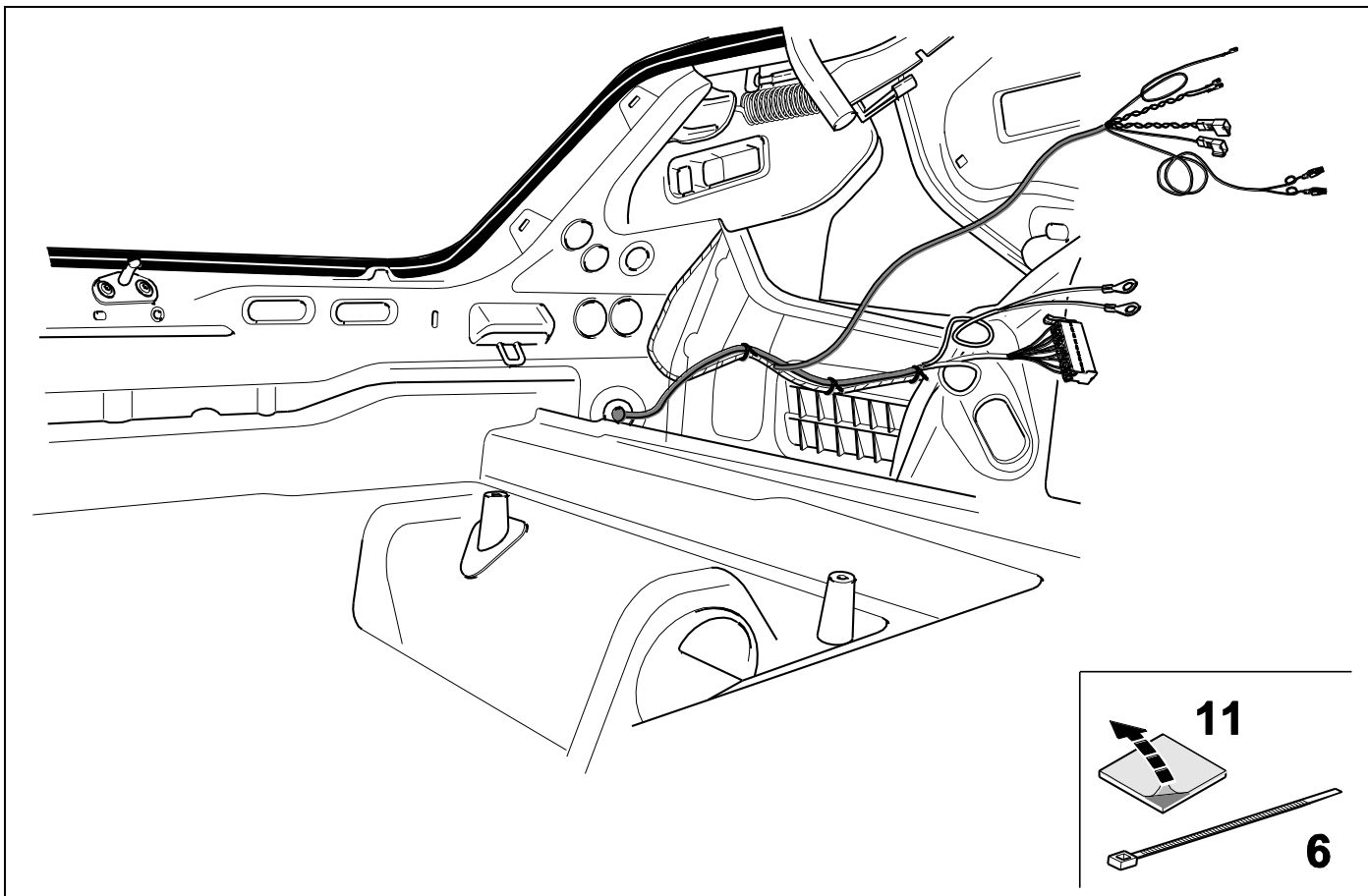

11



13

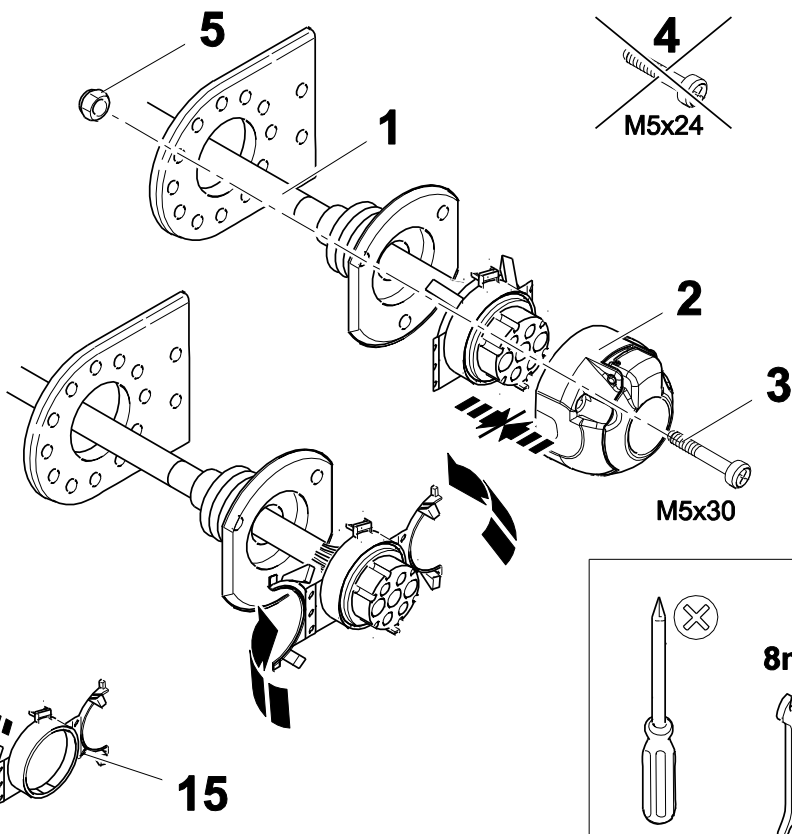
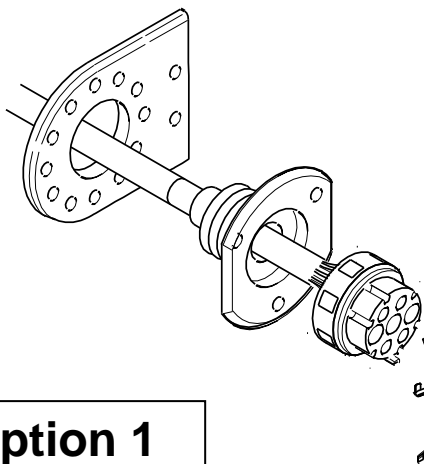
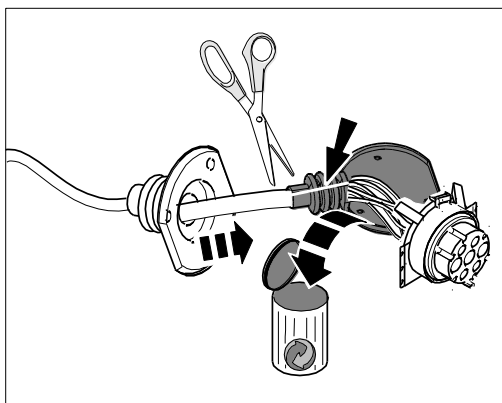

Option 1

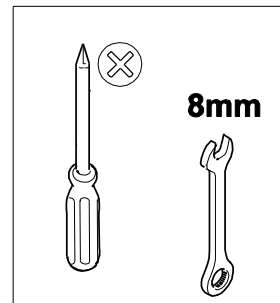

12



13

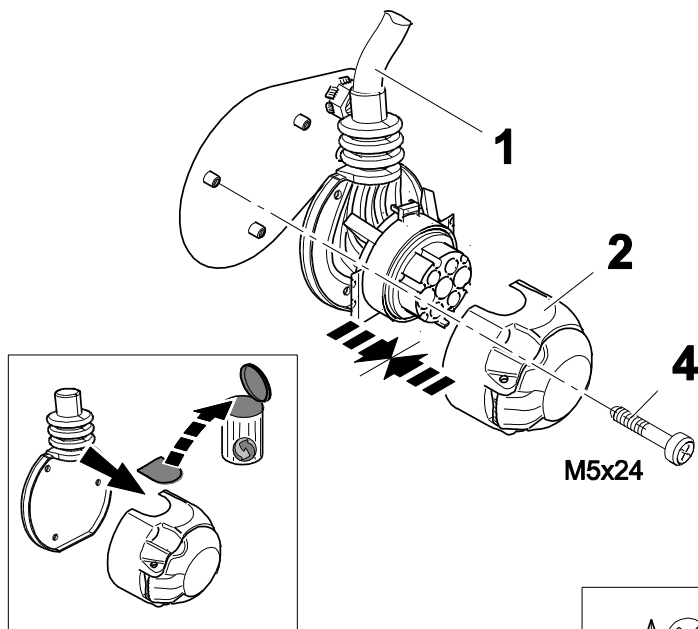
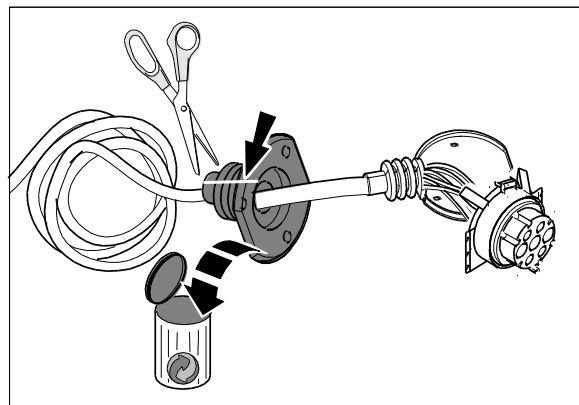
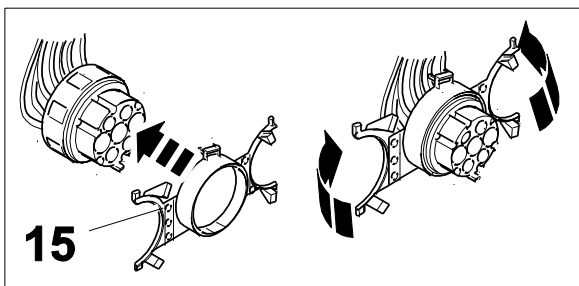

Option 2

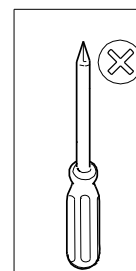



1/L	bk/wh	
2/54g	gy	
3/31	bn	
4/R	bk/gn	
5/58R	gy/rd	
6/54	bk/rd	
7/58L	gy/bk	

14	bk	wh	gy	gn	rd	bu	ye	bn	pu	or	no
(D)	schwarz	weiss	grau	grün	rot	blau	gelb	braun	violett	orange	nicht belegt
(GB)	black	white	grey	green	red	blue	yellow	brown	purple	orange	not occupied
(F)	noir	blanc	gris	vert	rouge	bleu	jaune	brun	violet	orange	inutilisé
(NL)	zwart	wit	grijs	groen	rood	blauw	geel	bruin	violet	oranje	niet aangesloten
(DK)	sort	hvid	grå	grøn	rød	blå	gul	brun	violet	orange	ikke anvendt
(N)	svart	hvit	grå	grønn	rød	blå	gul	brun	fiolett	oransje	ikke i bruk
(S)	svart	vit	grå	grön	röd	blå	gul	brun	violett	orange	ej använd
(FIN)	musta	valkoinen	harmaa	vihreä	punainen	sininen	keltainen	ruskea	violetti	oranssi	ei varattu
(I)	nero	bianco	grigio	verde	rosso	blu	giallo	marrone	viola	arancione	libero
(E)	negro	blanco	gris	verde	rojo	azul	amarillo	marrón	violeta	anaranja-do	no ocupado
(P)	preto	branco	cinzento	verde	vermelho	azul	amarelo	castanho	violeta	laranja	não ocupado
(GR)	μαύρος	λευκός	Γκρι	πράσινος	κόκκινος	μπλε	κίτρινος	καφέ	Μωβ	πορτοκαλί	δεν είναι κατ ελημμένος
(PL)	czarny	biały	szary	zielony	czerwony	niebiesko	żółty	brazowy	fioletowy	pomarańczowy	wolny
(CZ)	černý	bílý	šedý	zelený	červený	modrý	žlutý	hnědý	fialový	oranžový	neobsazen
(TR)	siyah	beyaz	gri	yeşil	kırmızı	mavi	sarı	kahverengi	mor	portakal rengi	boş
(H)	fekete	fehér	szürke	zöld	piros	kék	sárga	barna	ibolyakék	narancssárga	nem foglalt
(HR)	crno	bijelo	sivo	zeleno	crveno	plavo	zuto	smeđe	ljubičasto	narandasto	nije zauzeto
(BUL)	черен	бял	сив	зелен	червен	син	жълт	кафяв	виолетов	оранжев	свободно
(RO)	negru	alb	gri	verde	roșu	albastru	galben	maro	violet	portocaliu	liber
(RU)	черный	белый	серый	зеленый	красный	голубой	жёлтый	коричневый	пурпурный	оранжевый	свободно
(LT)	juoda	balta	pilka	žalia	raudona	mėlyna	geltona	ruda	purpurinė	oranžinė	laisva
(LV)	melna	balta	pelēka	zaļa	sarkana	zila	dzeltena	brūna	purpur-sarkana	oranža	brīvs
(EST)	must	valge	hall	roheline	punane	sinine	kollane	pruun	purpur-punane	oraanž	vaba
(SLO)	črna	bela	siva	zelena	rdeča	modra	rumena	smeđ	vijoličast	oranžen	ni zasedeno
(SK)	čierny	biely	šedý	zelený	červený	modrý	žltý	hnědý	fialový	pomaraňový	neobsadený

15

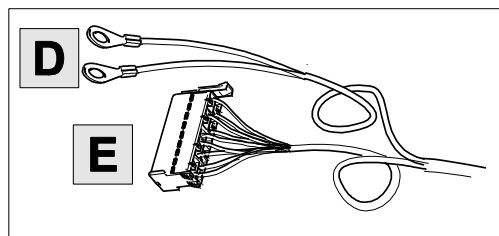
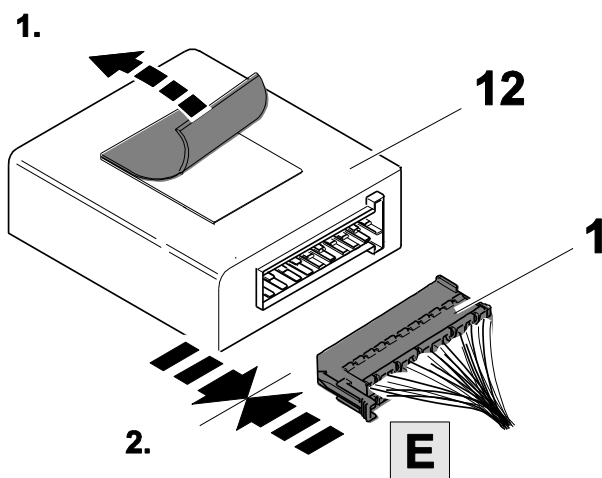

16

Passat Variant / Limousine / CC

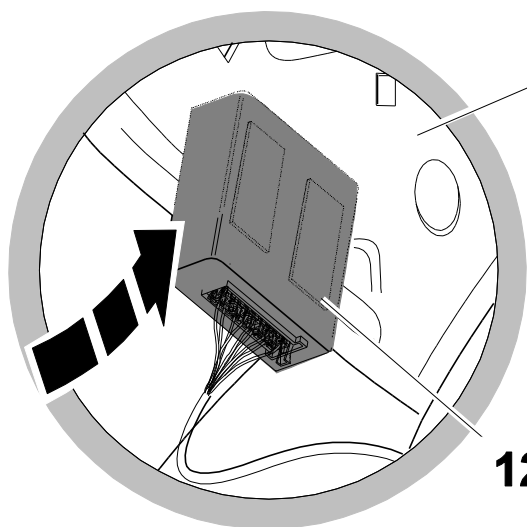
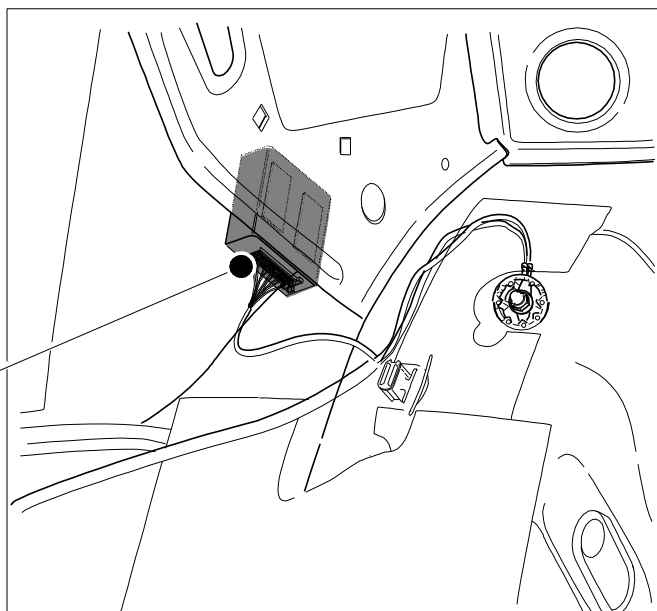
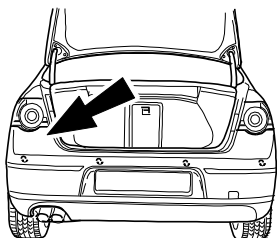

17

Passat Variant / Limousine / CC

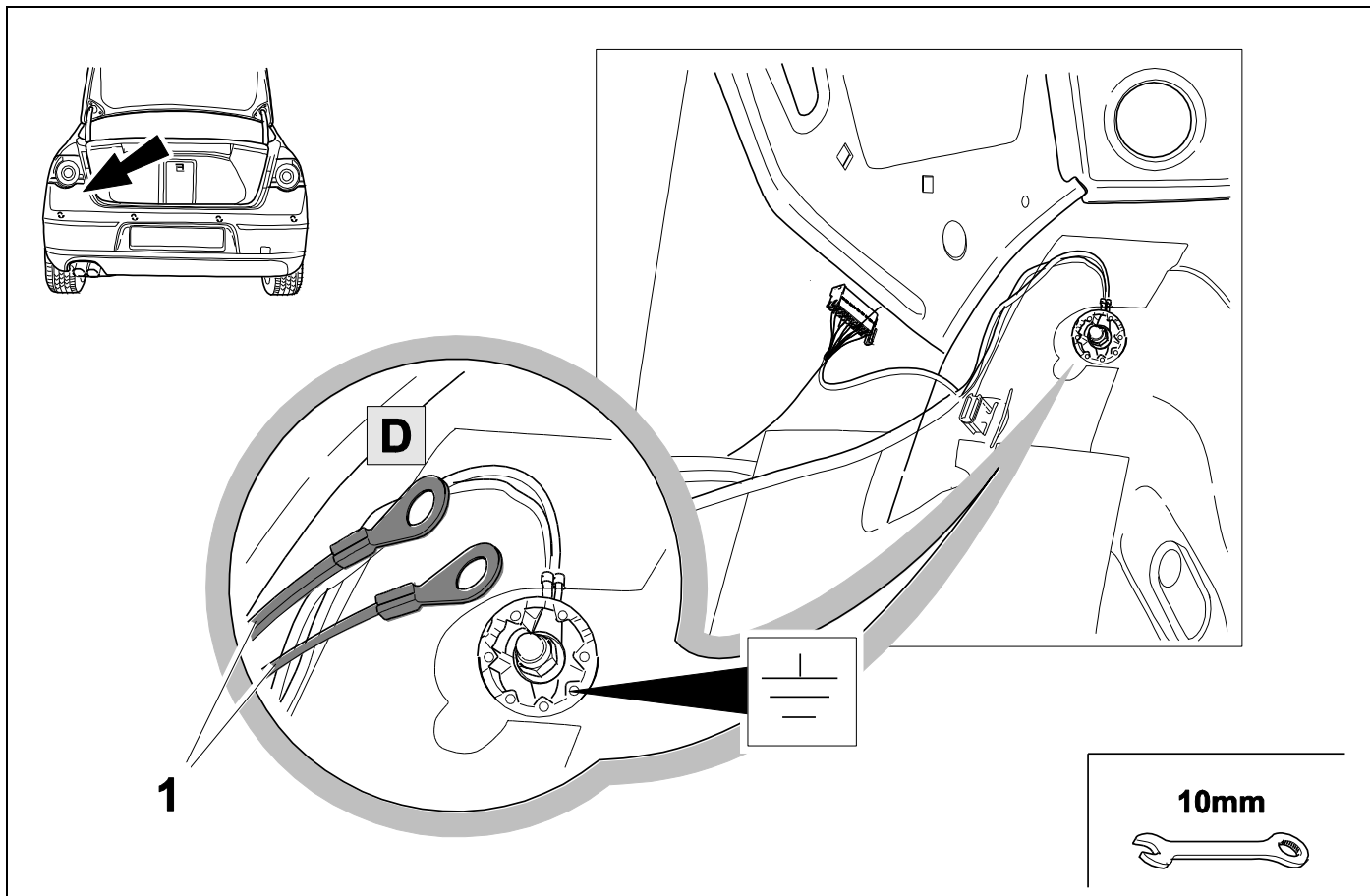

18

Jetta

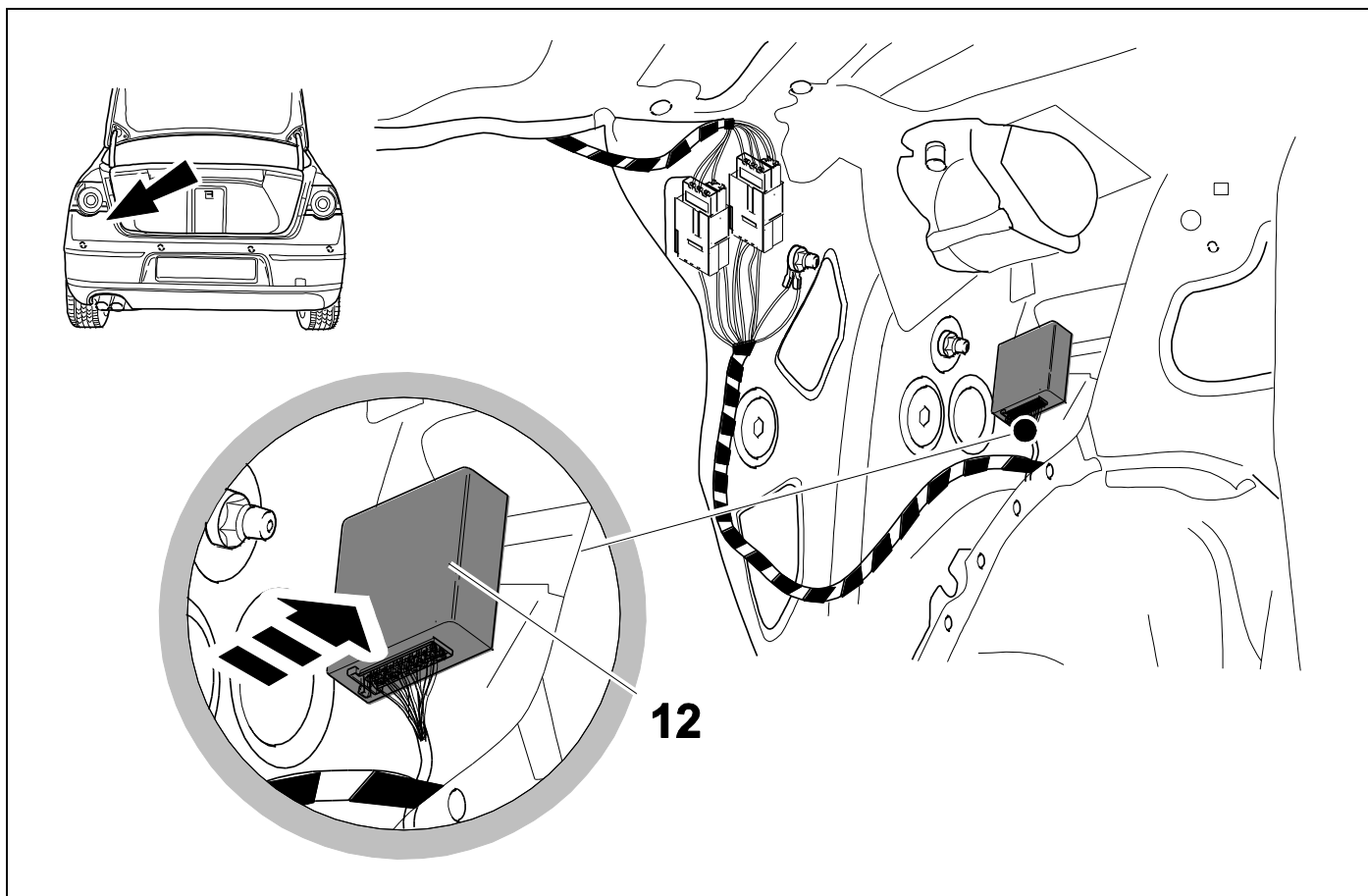

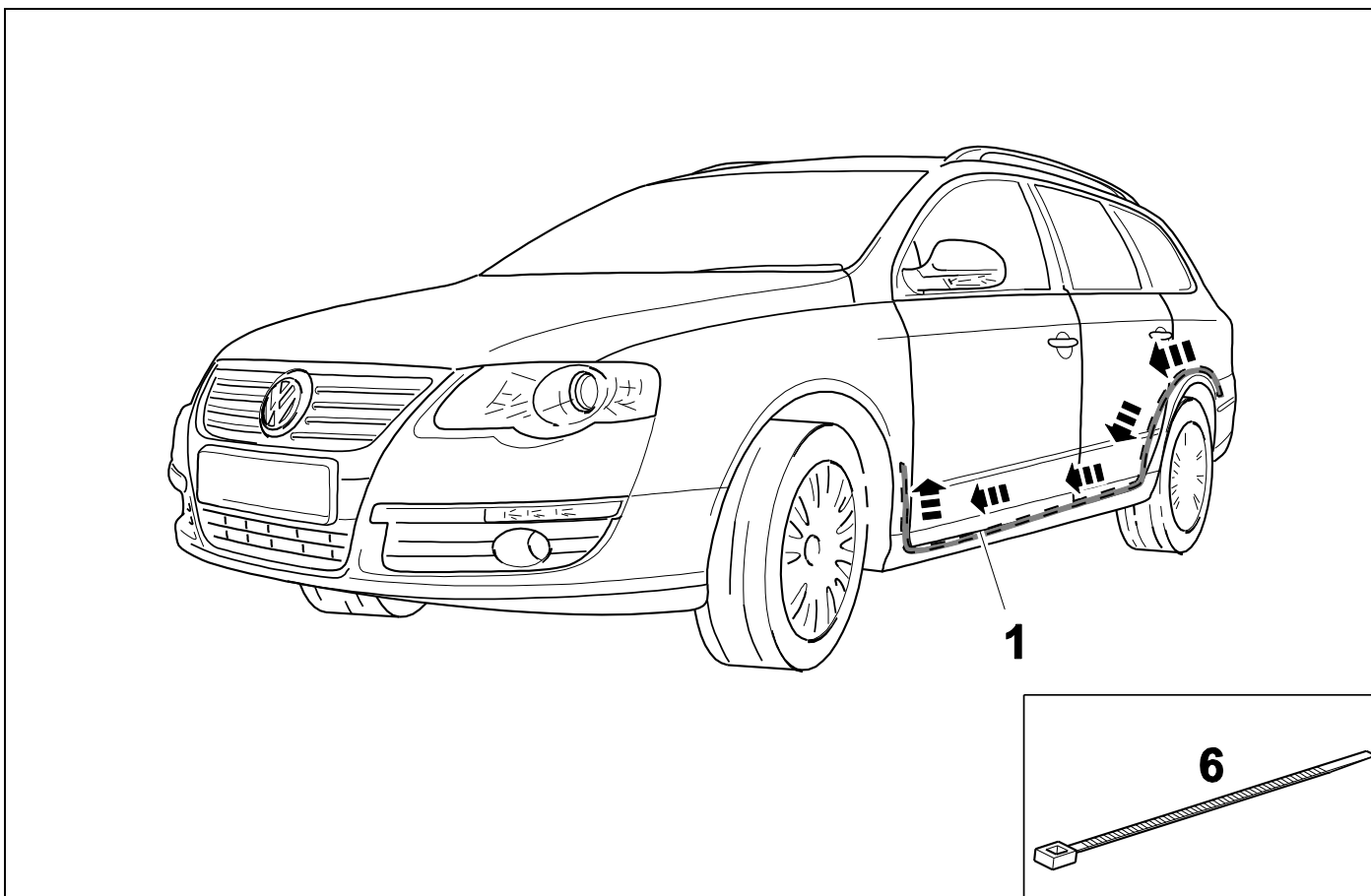
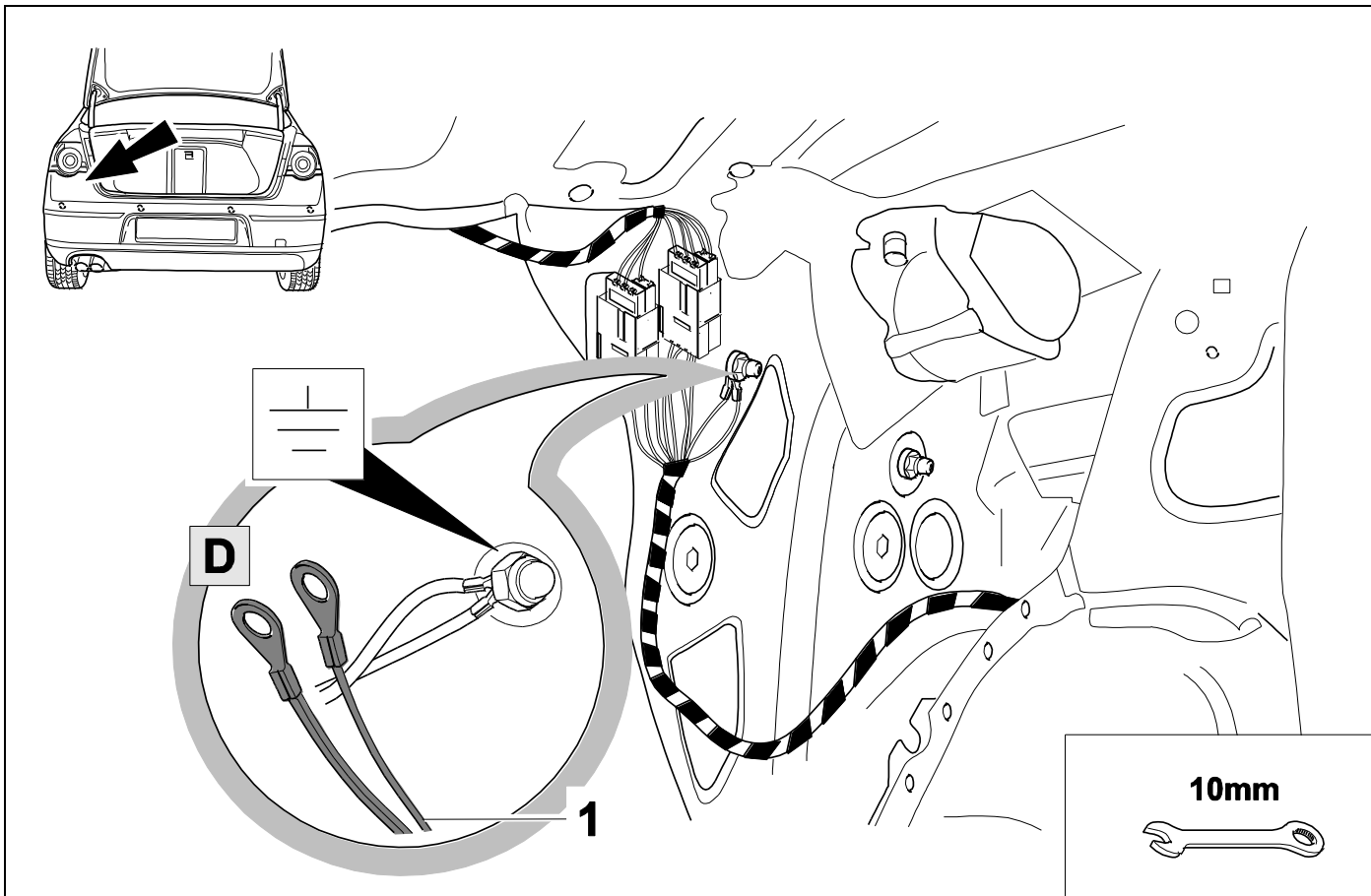

21

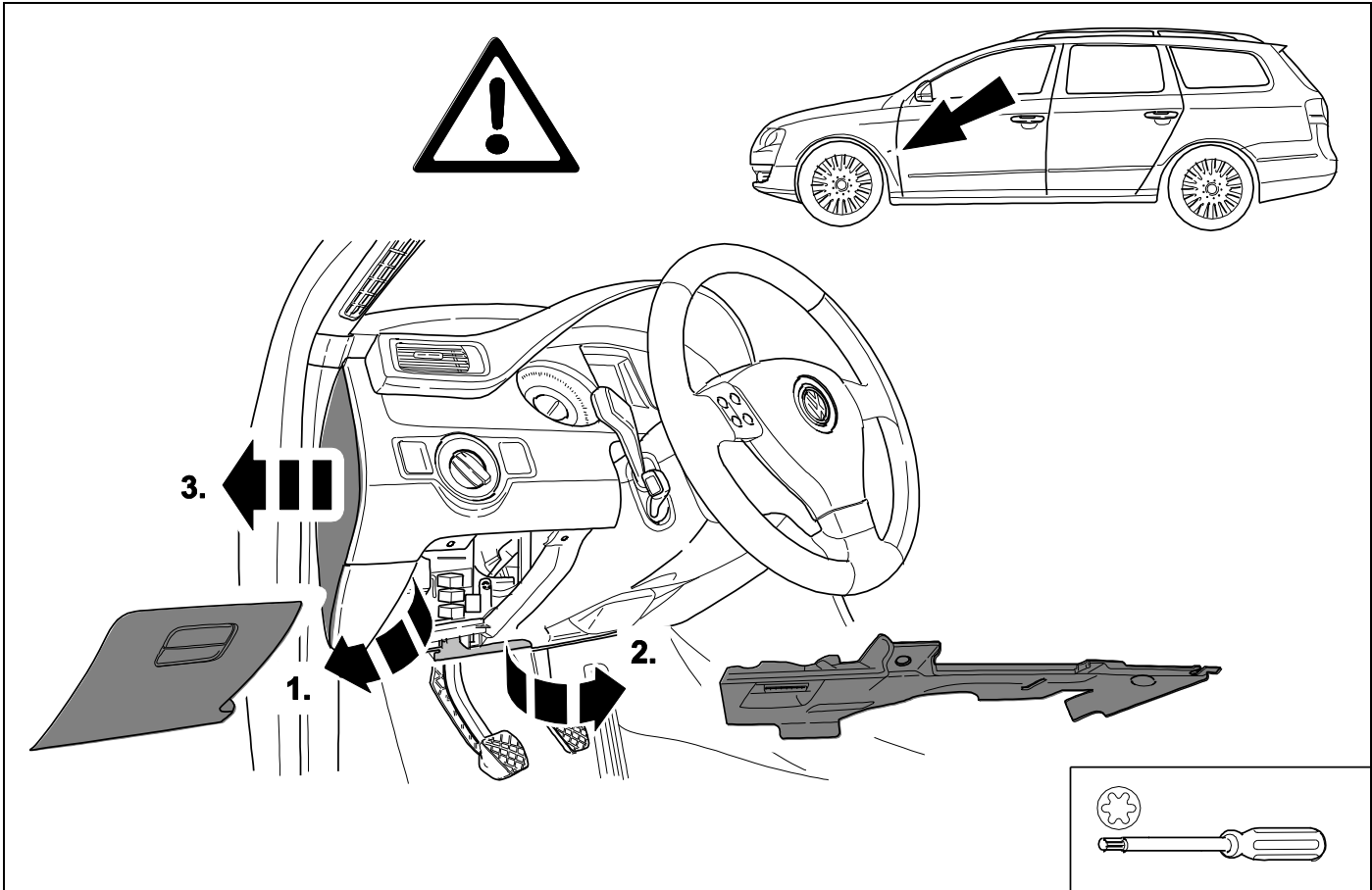

22

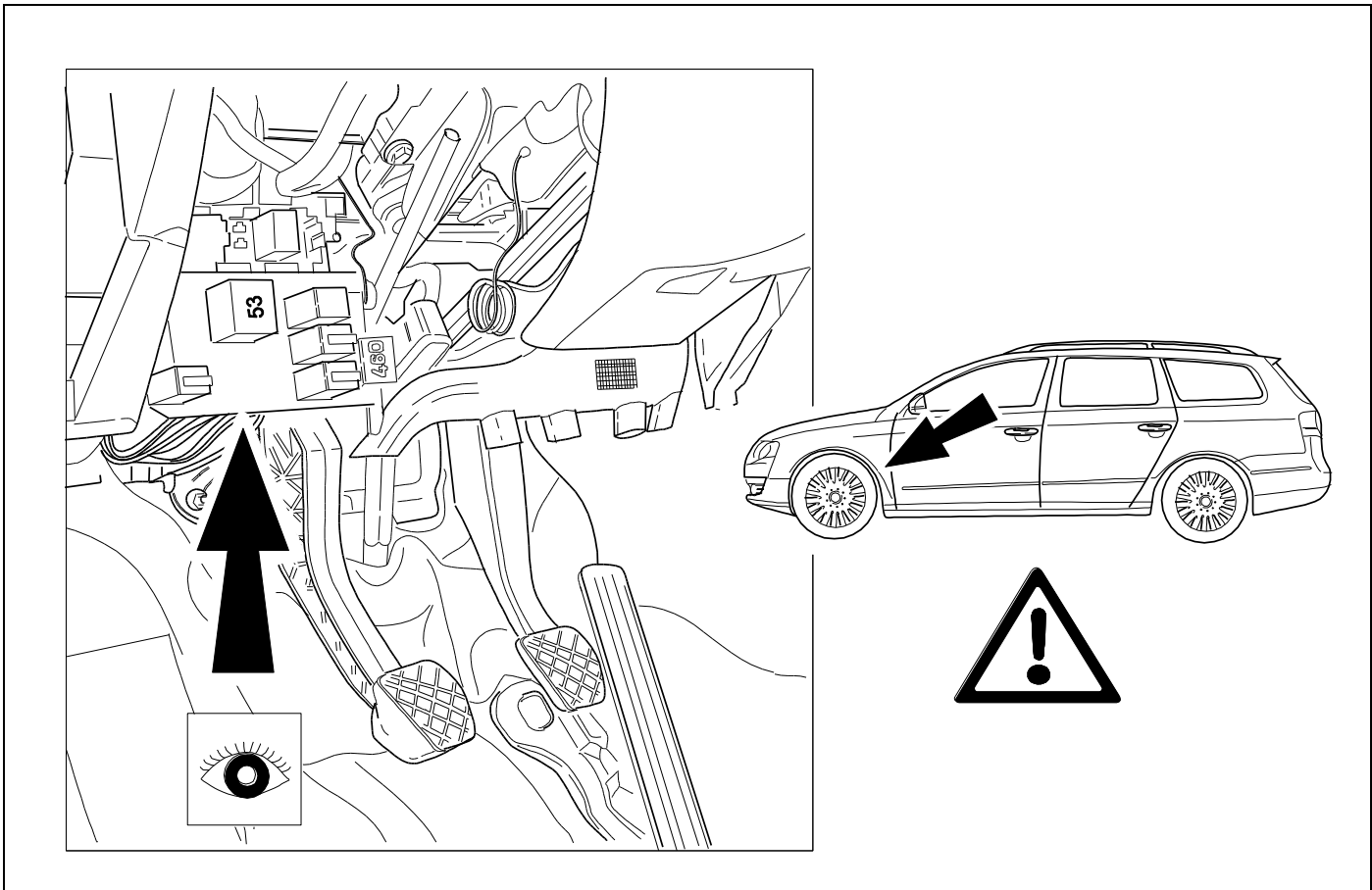

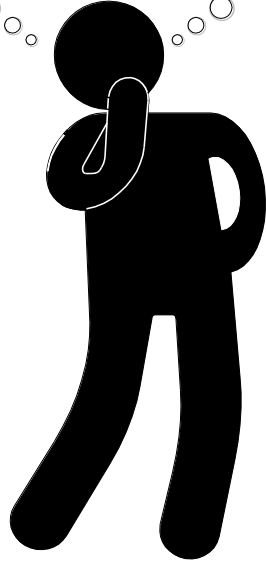
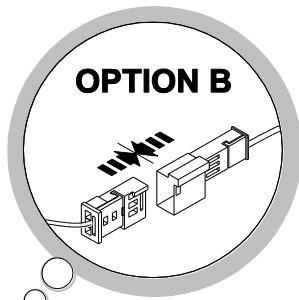
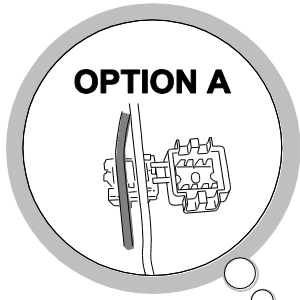

OPTION A

$$\begin{array}{r} \boxed{24} - \boxed{27} \\ + \\ \boxed{31} - \boxed{59} \end{array}$$

OPTION B

$$\begin{array}{r} \boxed{24} \\ + \\ \boxed{28} - \boxed{59} \end{array}$$

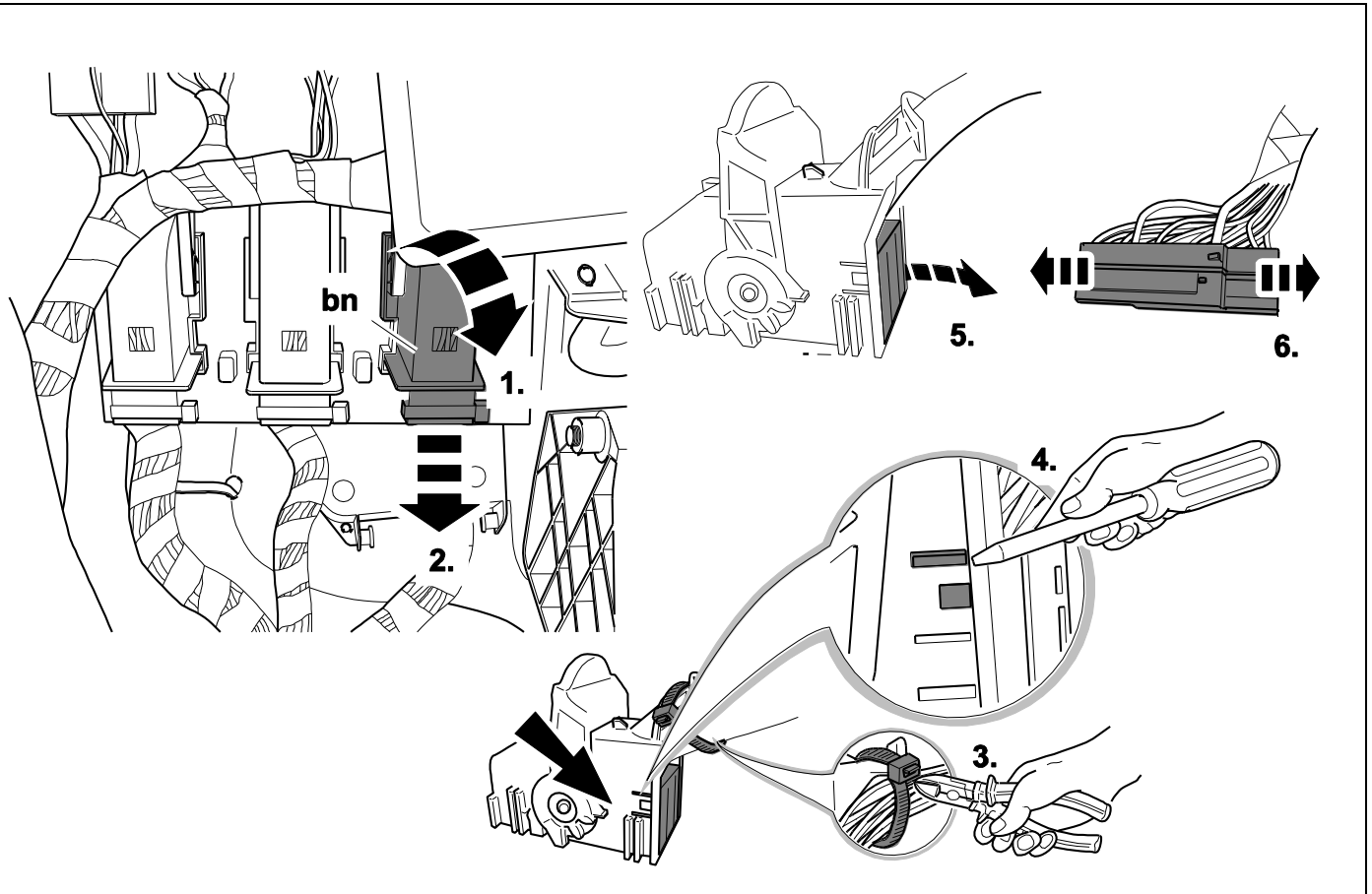

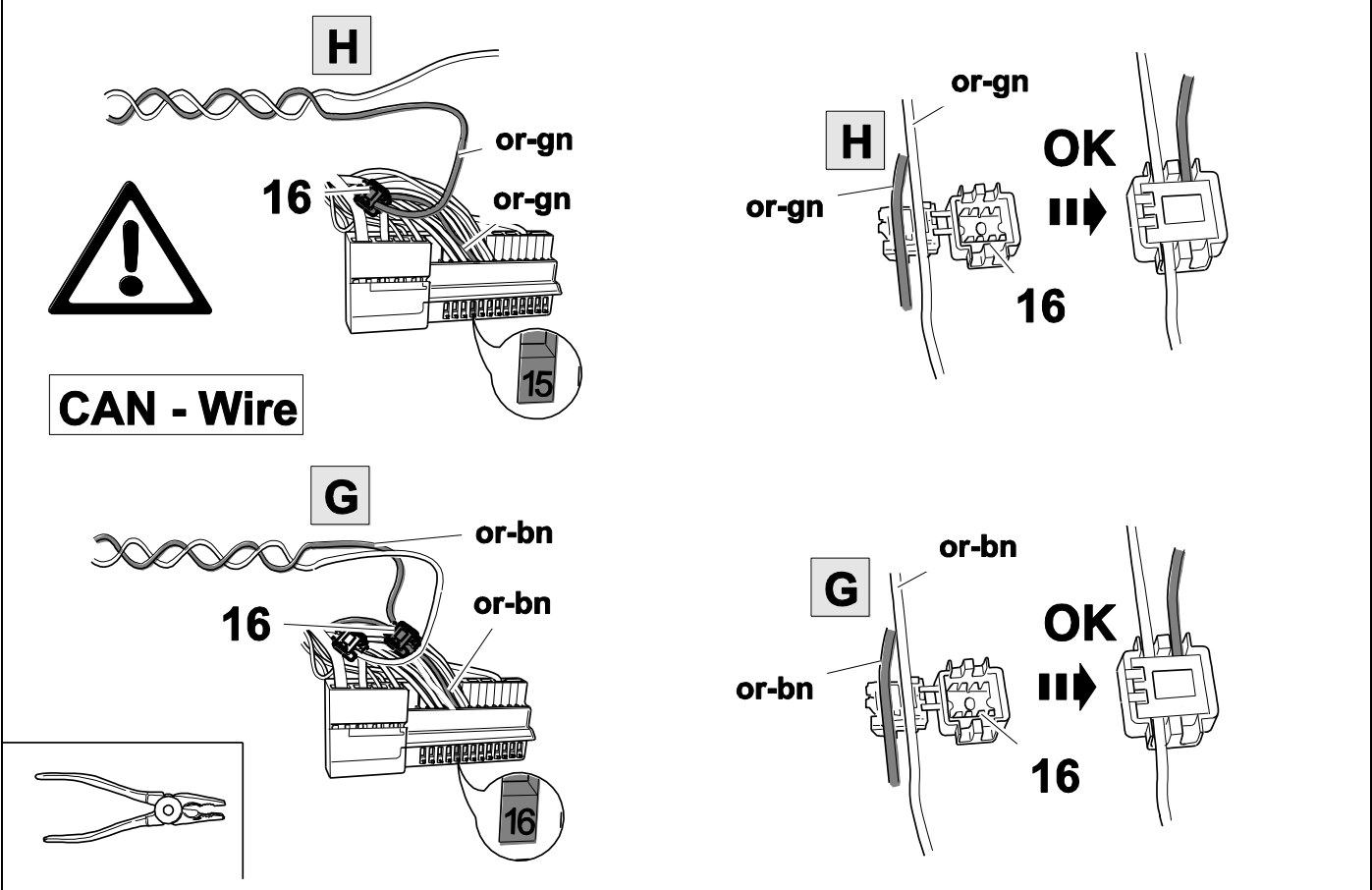
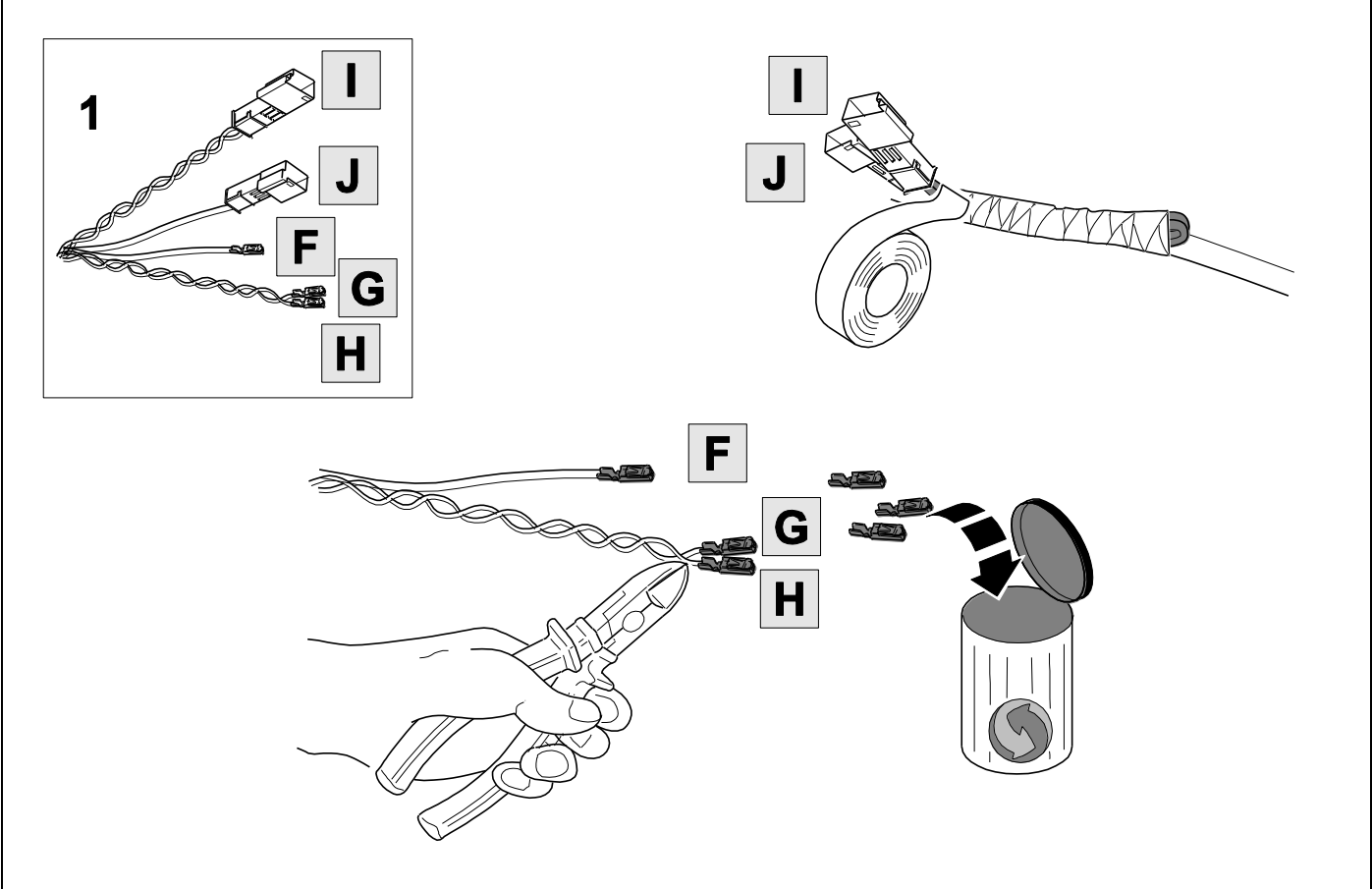

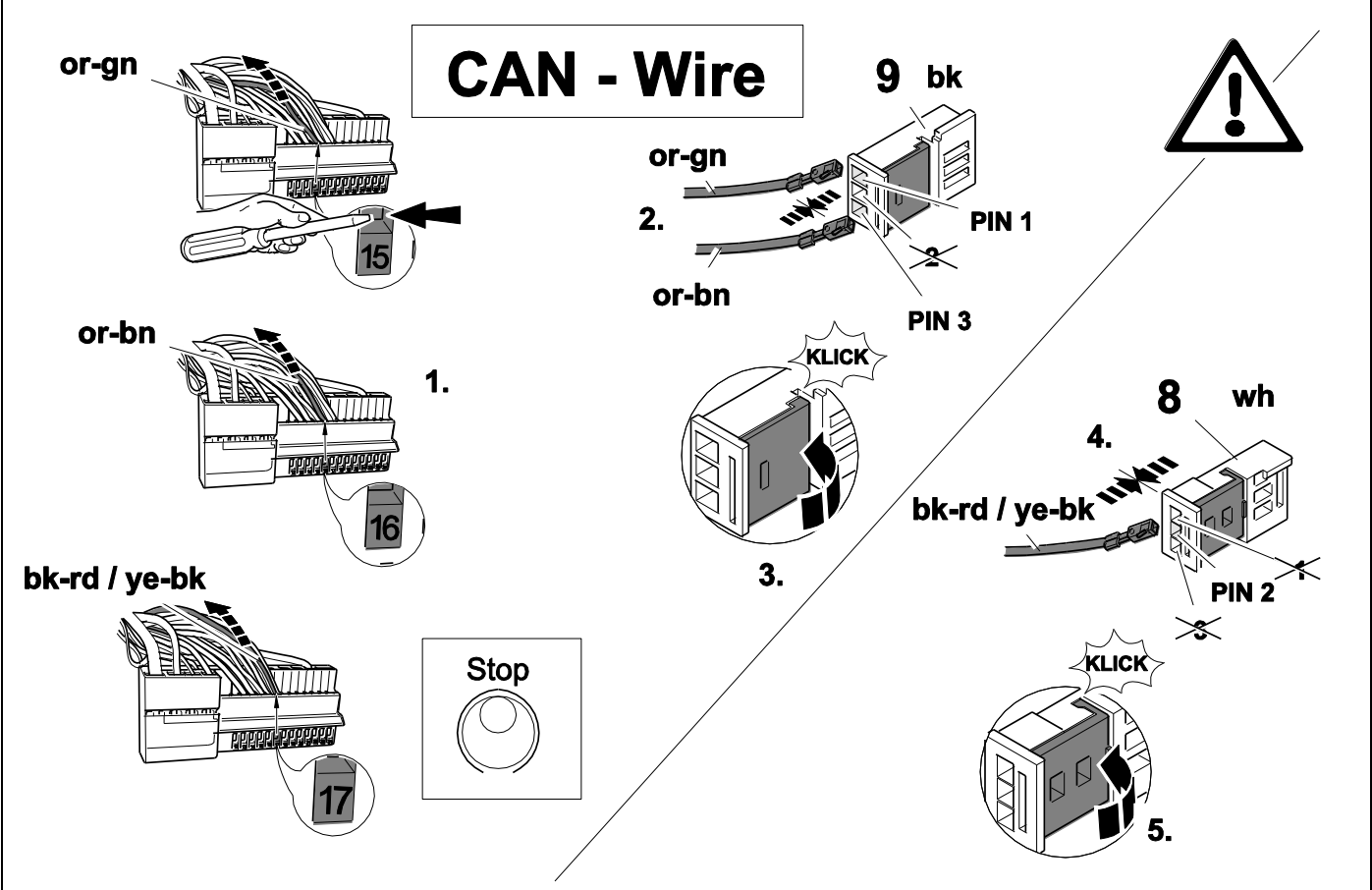
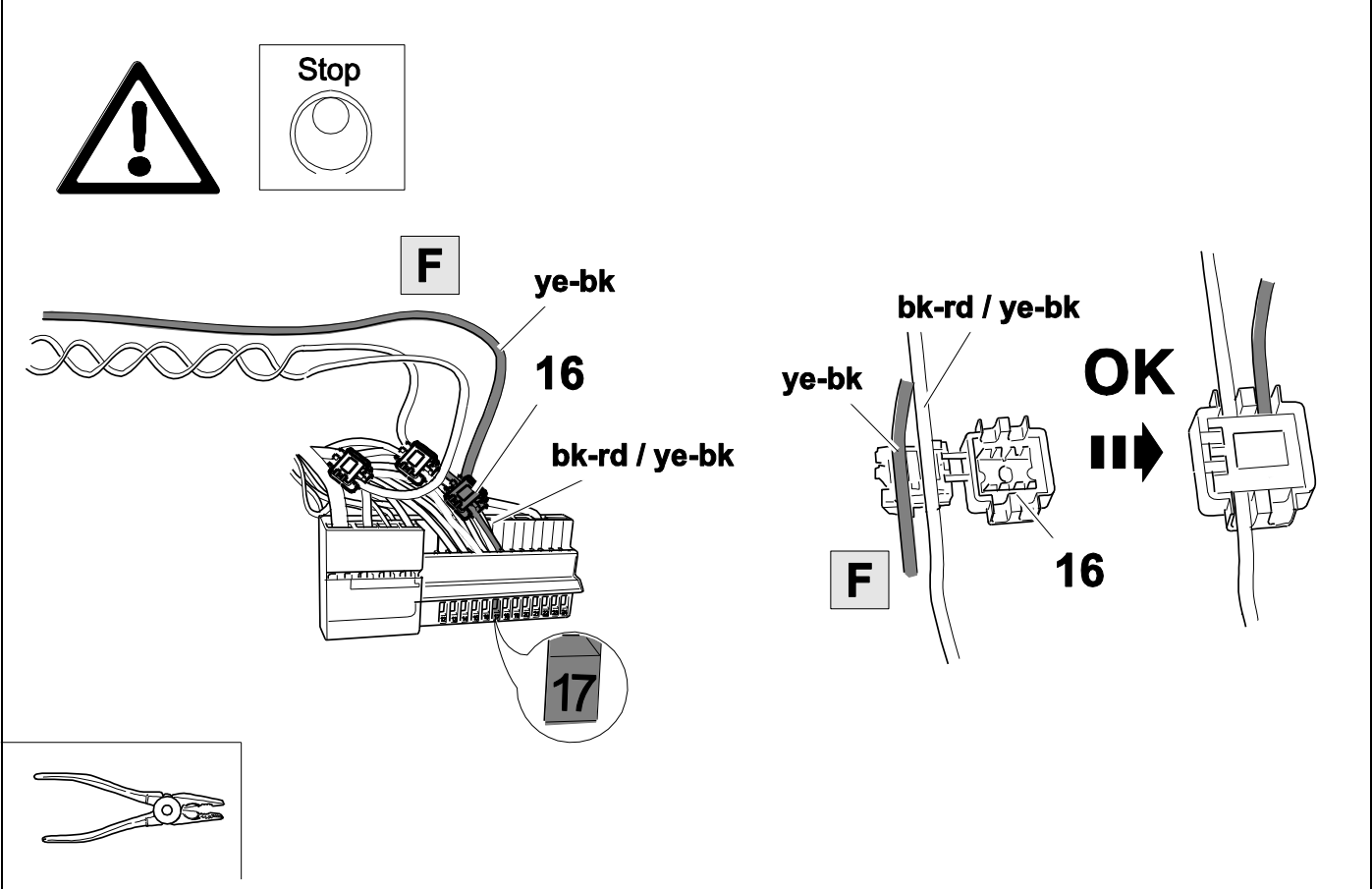

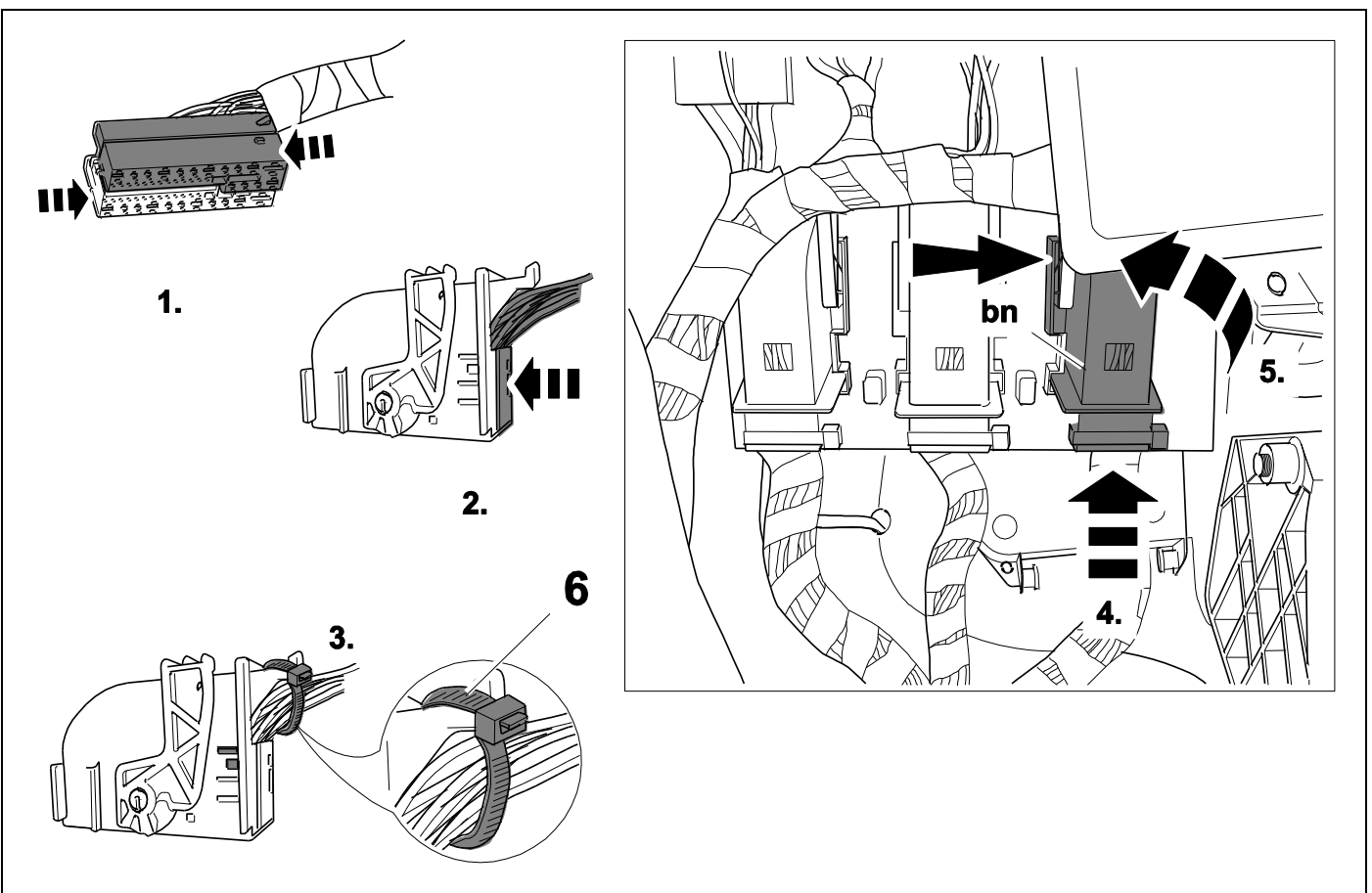
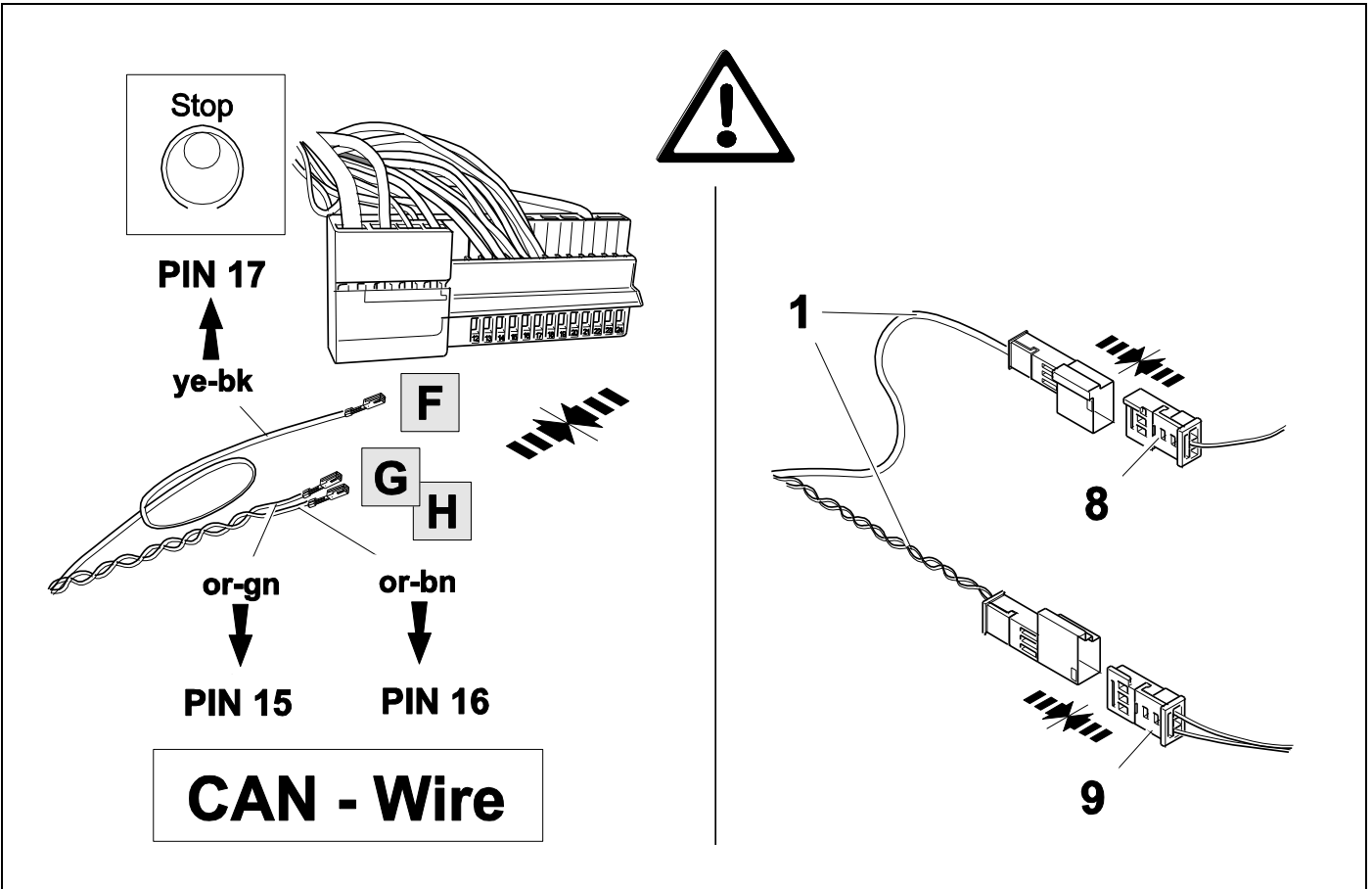

31

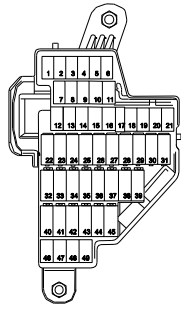

OPTION A



32 - 37

46 - 59

Passat Variant
Passat Limousine
Alltrack
Passat CC

→ 2010
→ 2010
→ 2012
→ 2012

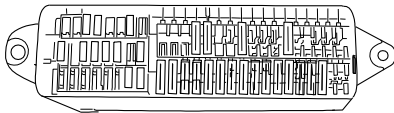

OPTION B



38 - 59

Jetta

→ 2011

32

OPTION A

Passat Variant / Limousine / CC

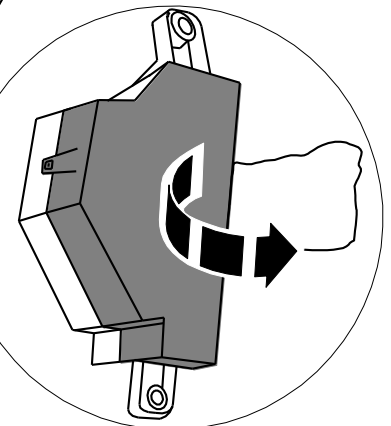
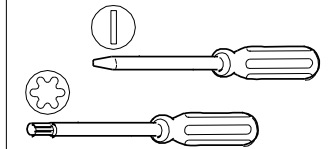
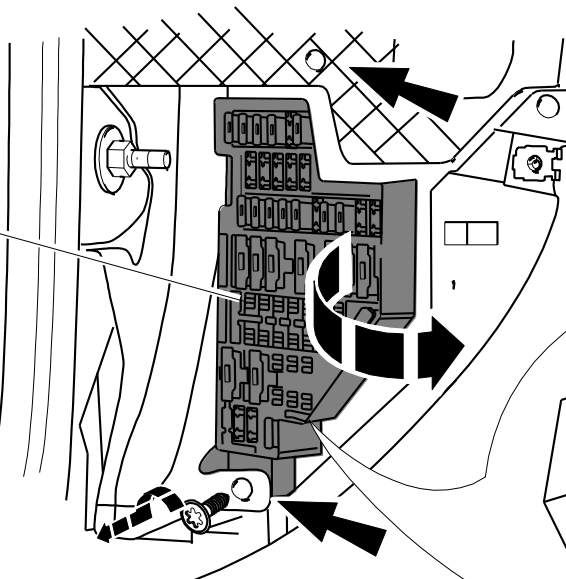
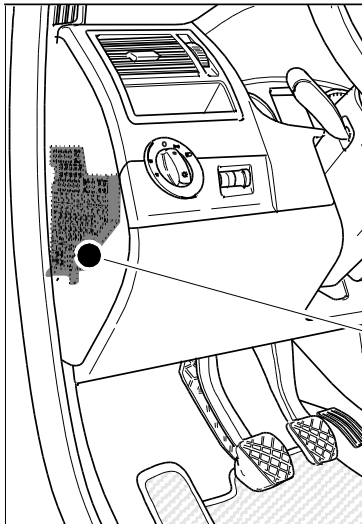

33

OPTION A

Passat Variant / Limousine / CC



Open secondary lock!
Sekundärverriegelung öffnen!

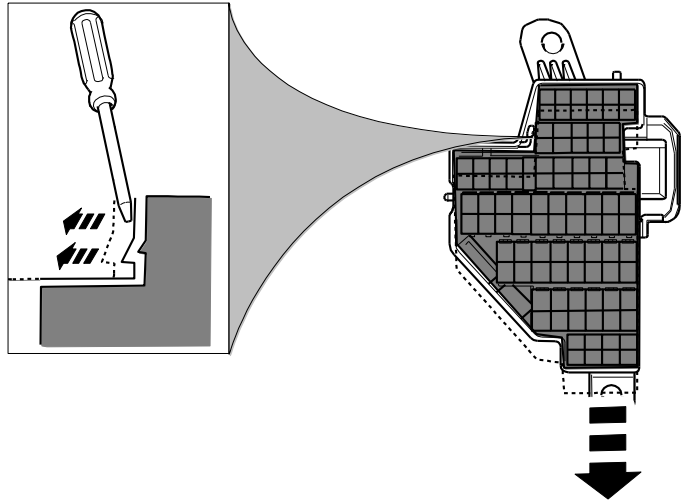

34

OPTION A

Passat Variant / Limousine / CC

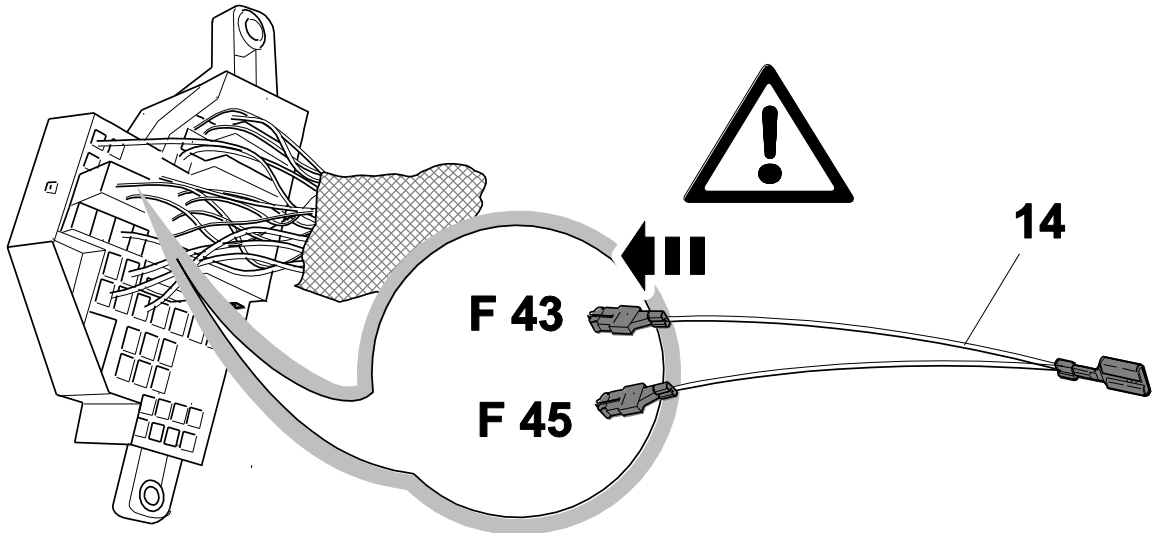

35

OPTION A

Passat Variant / Limousine / CC

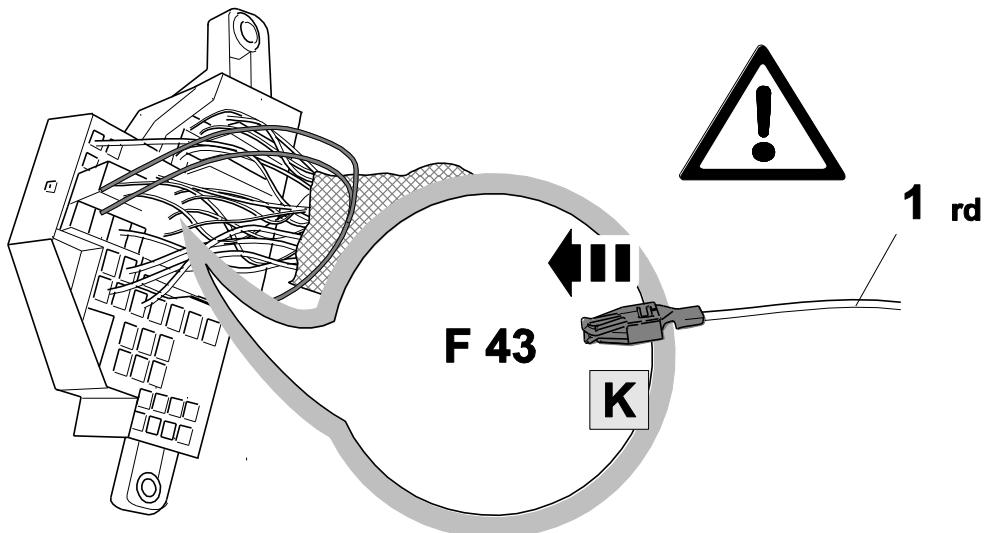

36

OPTION A

Passat Variant / Limousine / CC

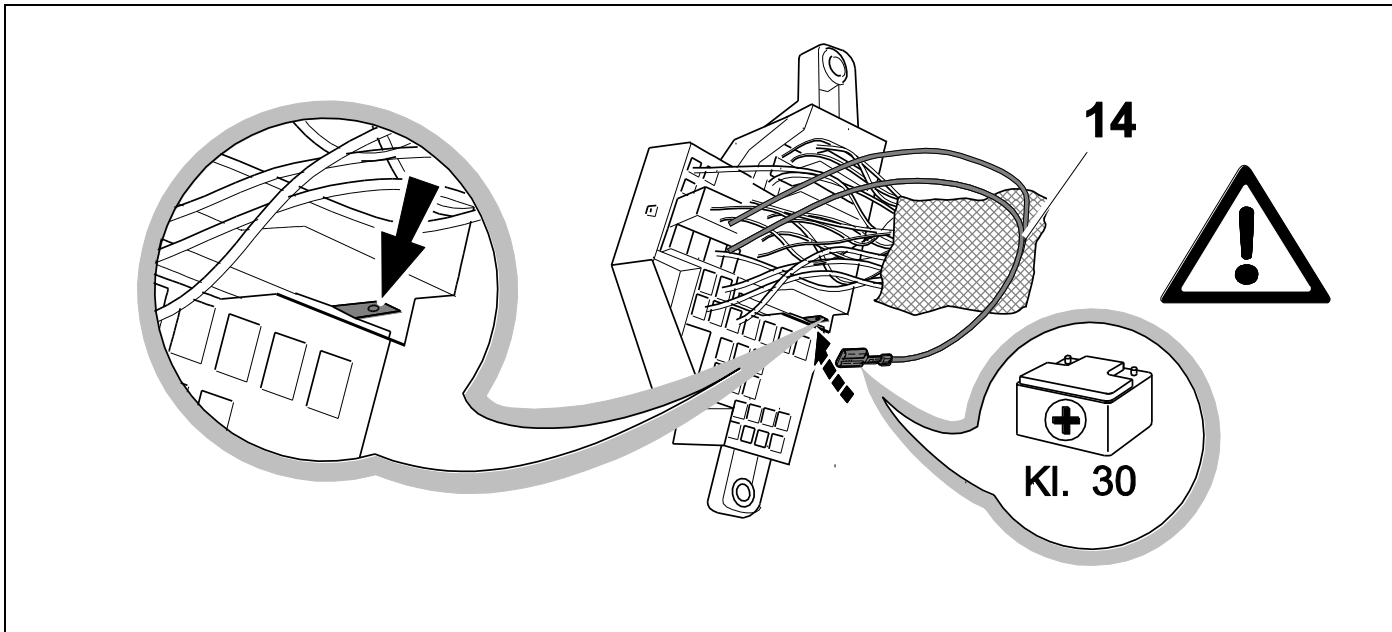

37

OPTION A



55

Passat Variant / Limousine / CC

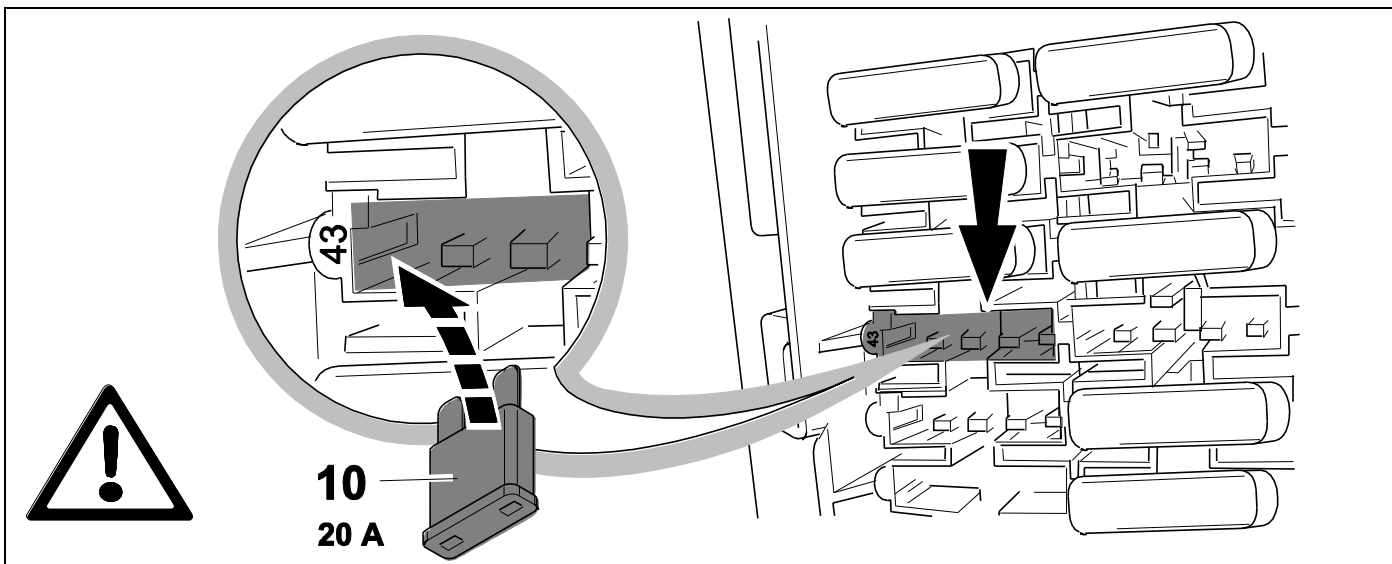

38

OPTION B

Jetta

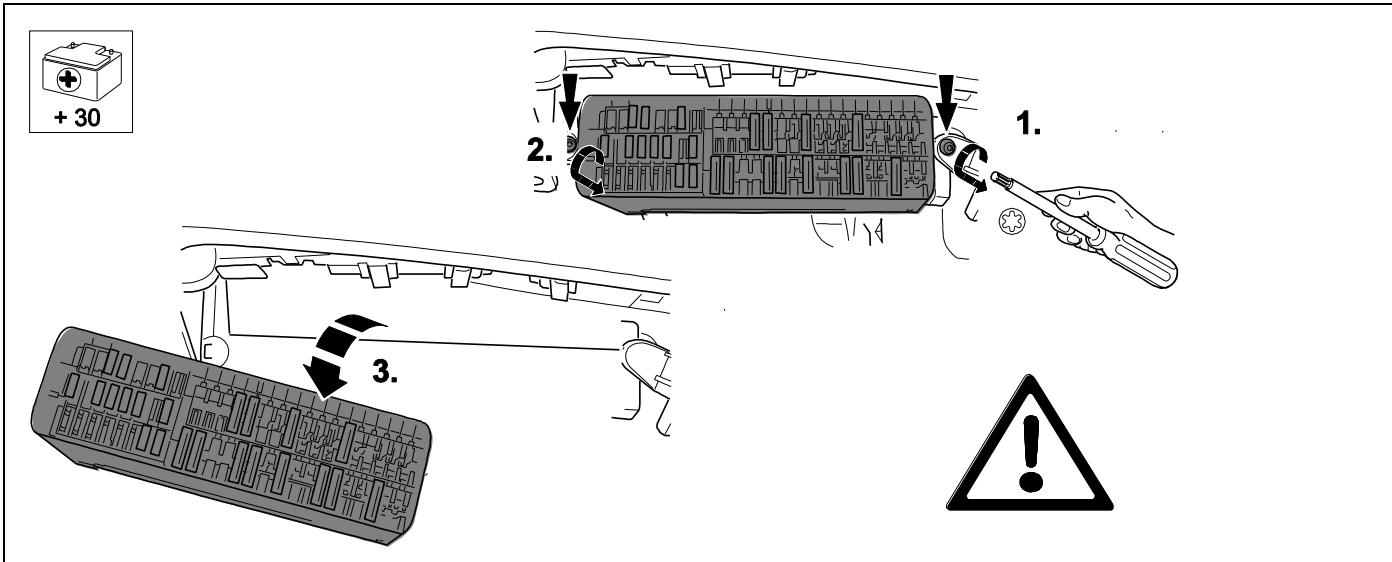

39

OPTION B

Jetta

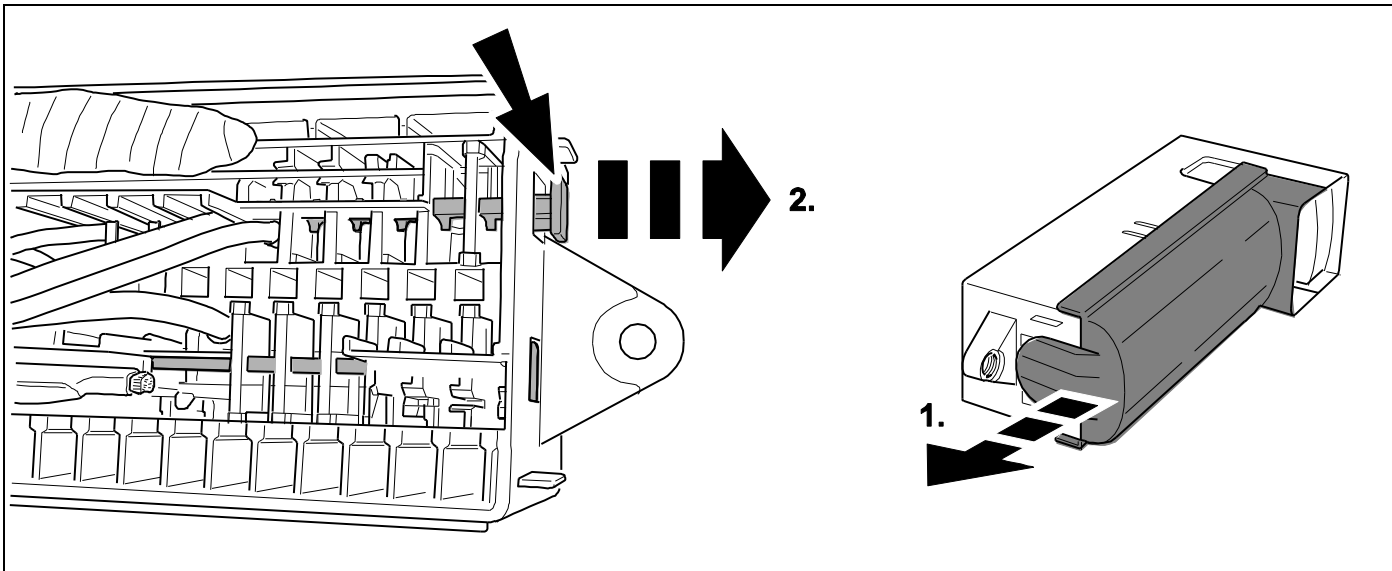

40 OPTION B

Jetta

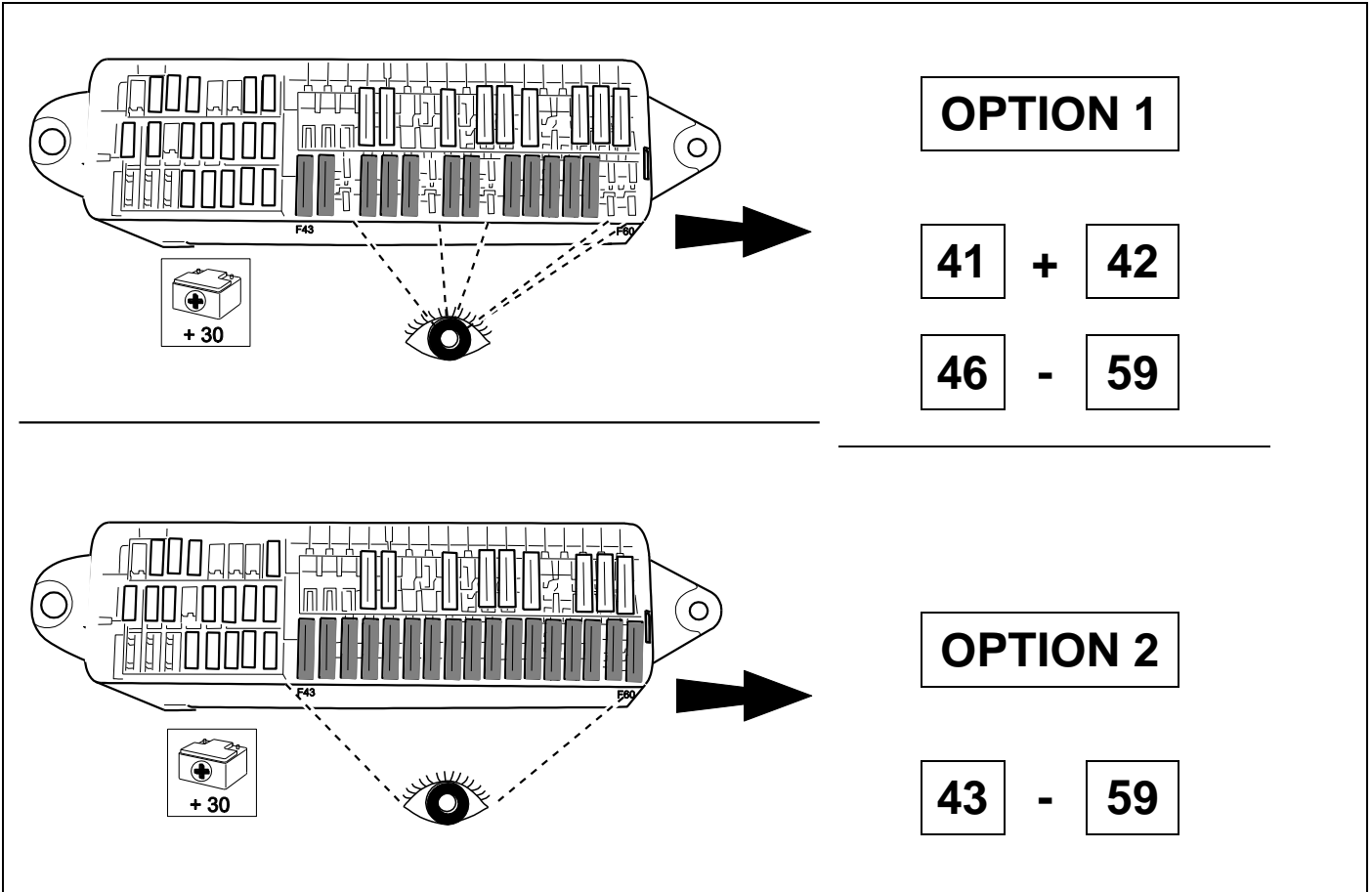

41 OPTION 1

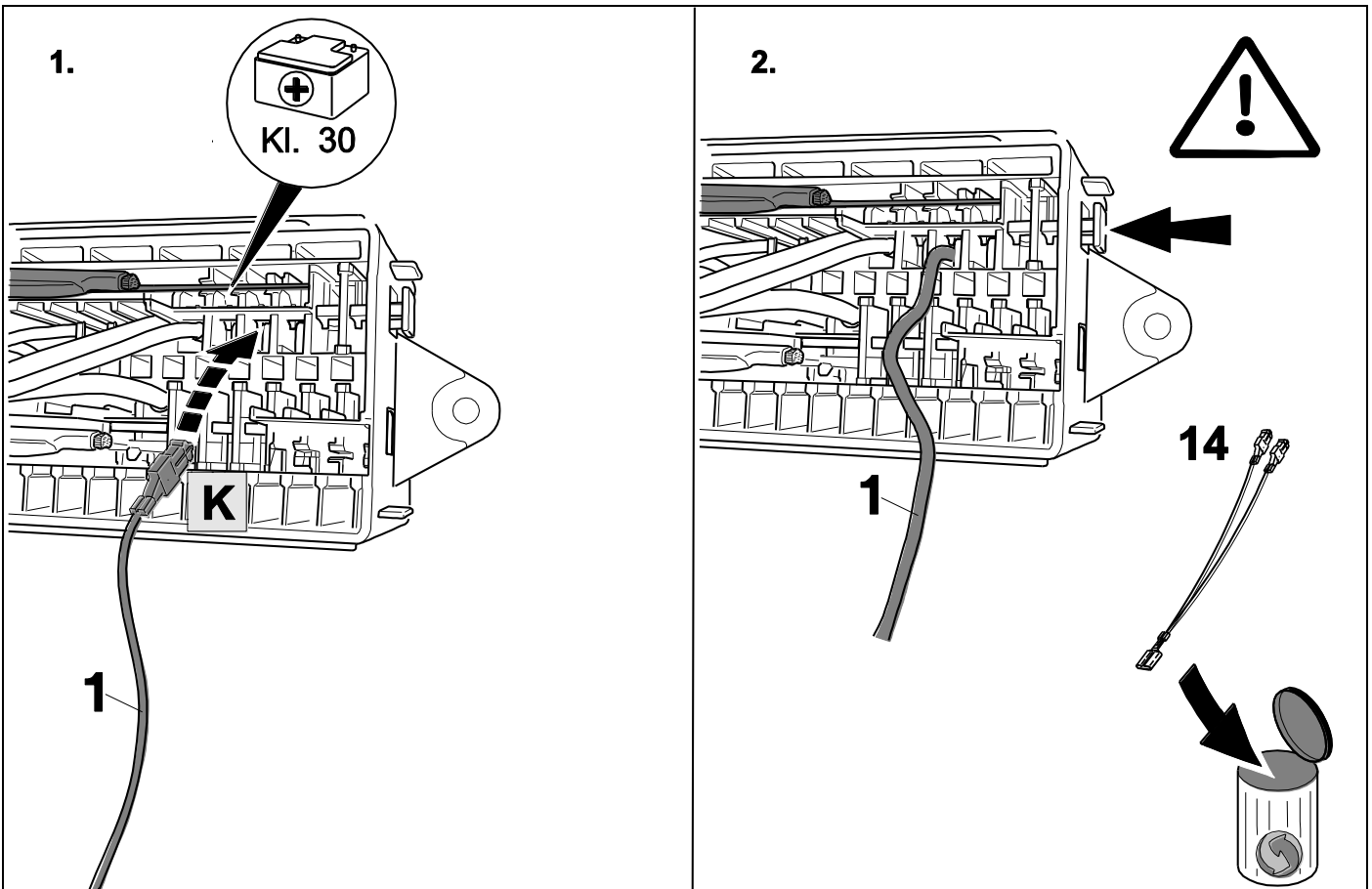

42 **OPTION 1**



55

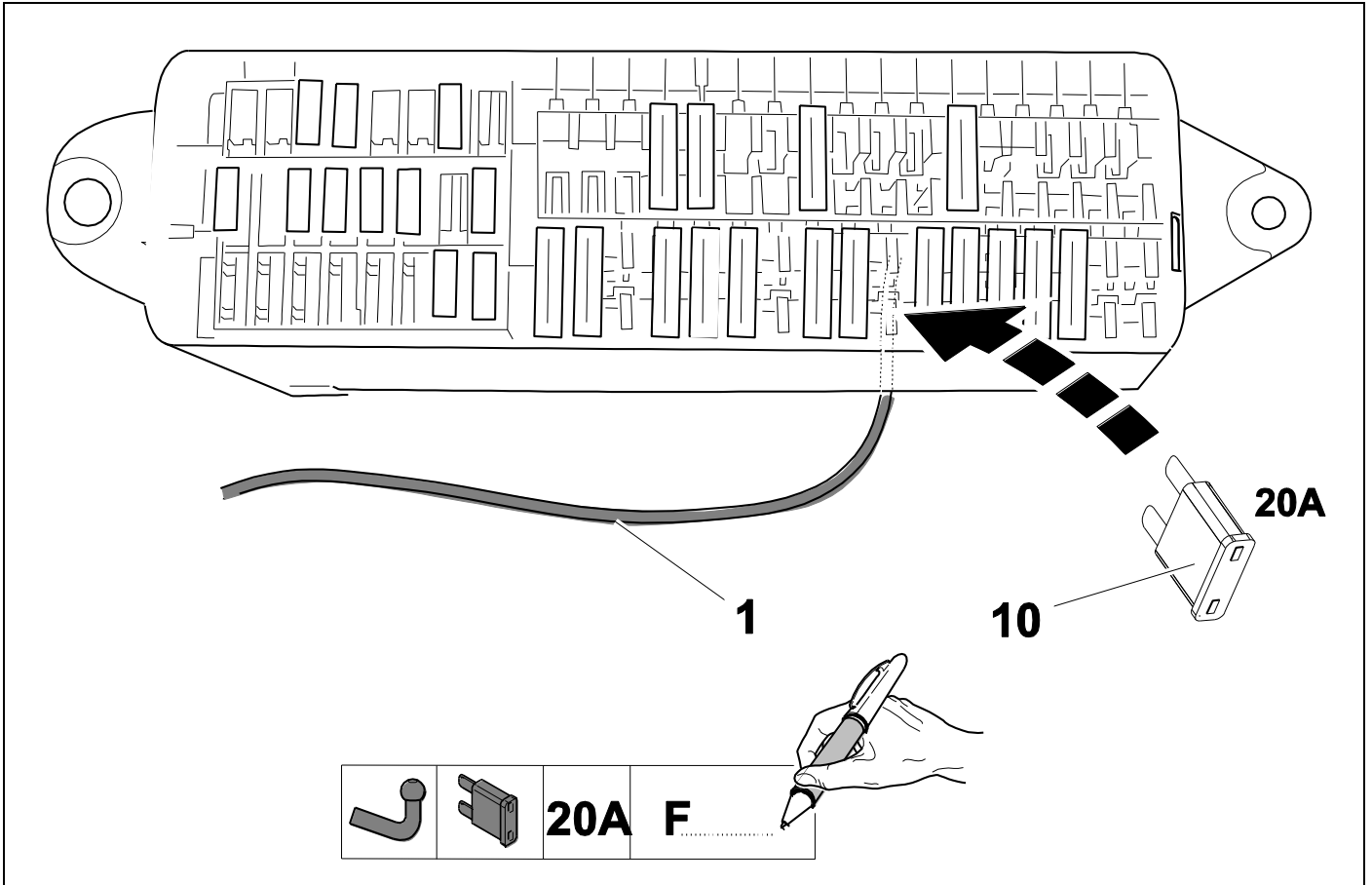

43 **OPTION 2**



14

Jetta

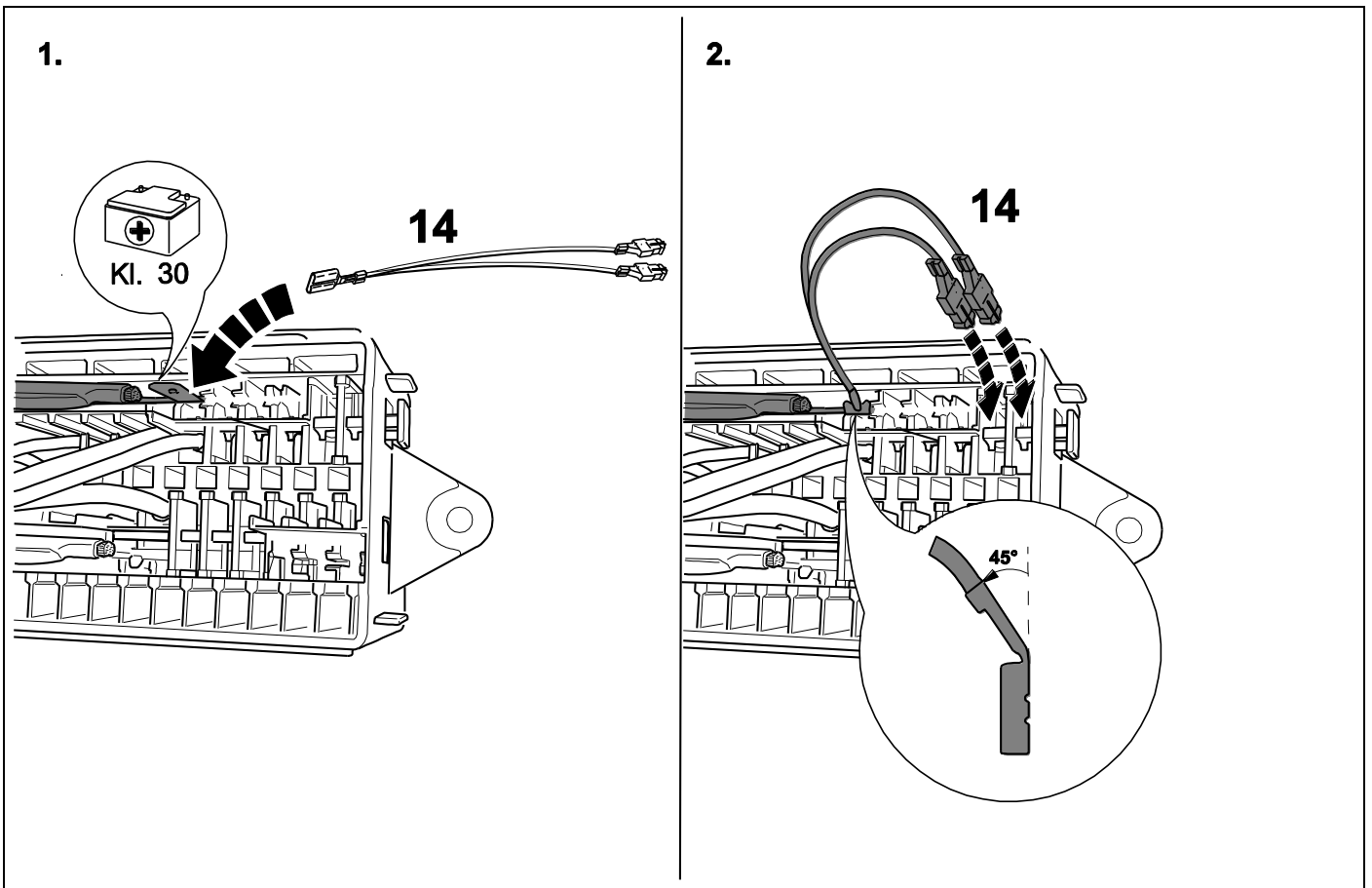

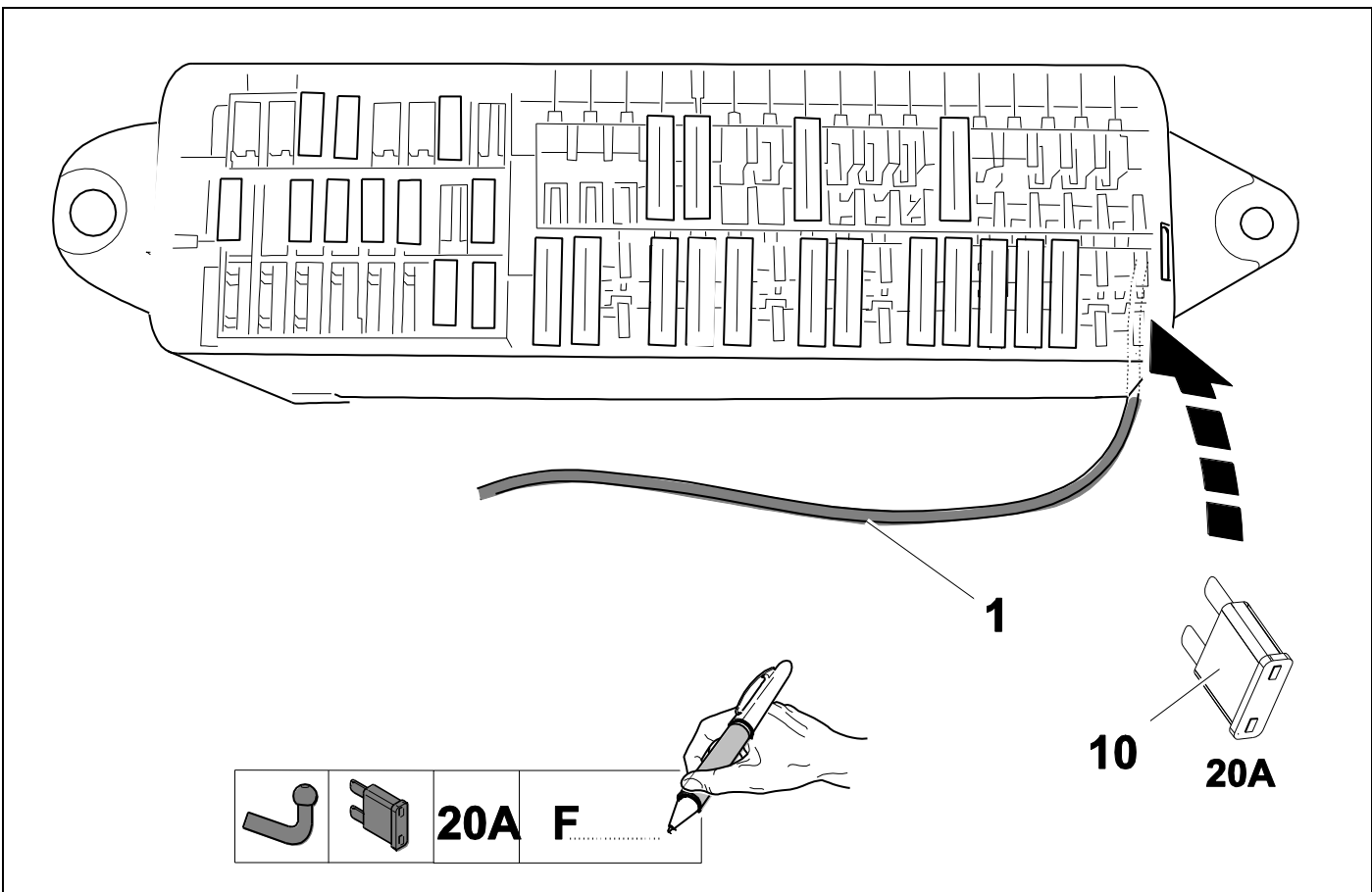
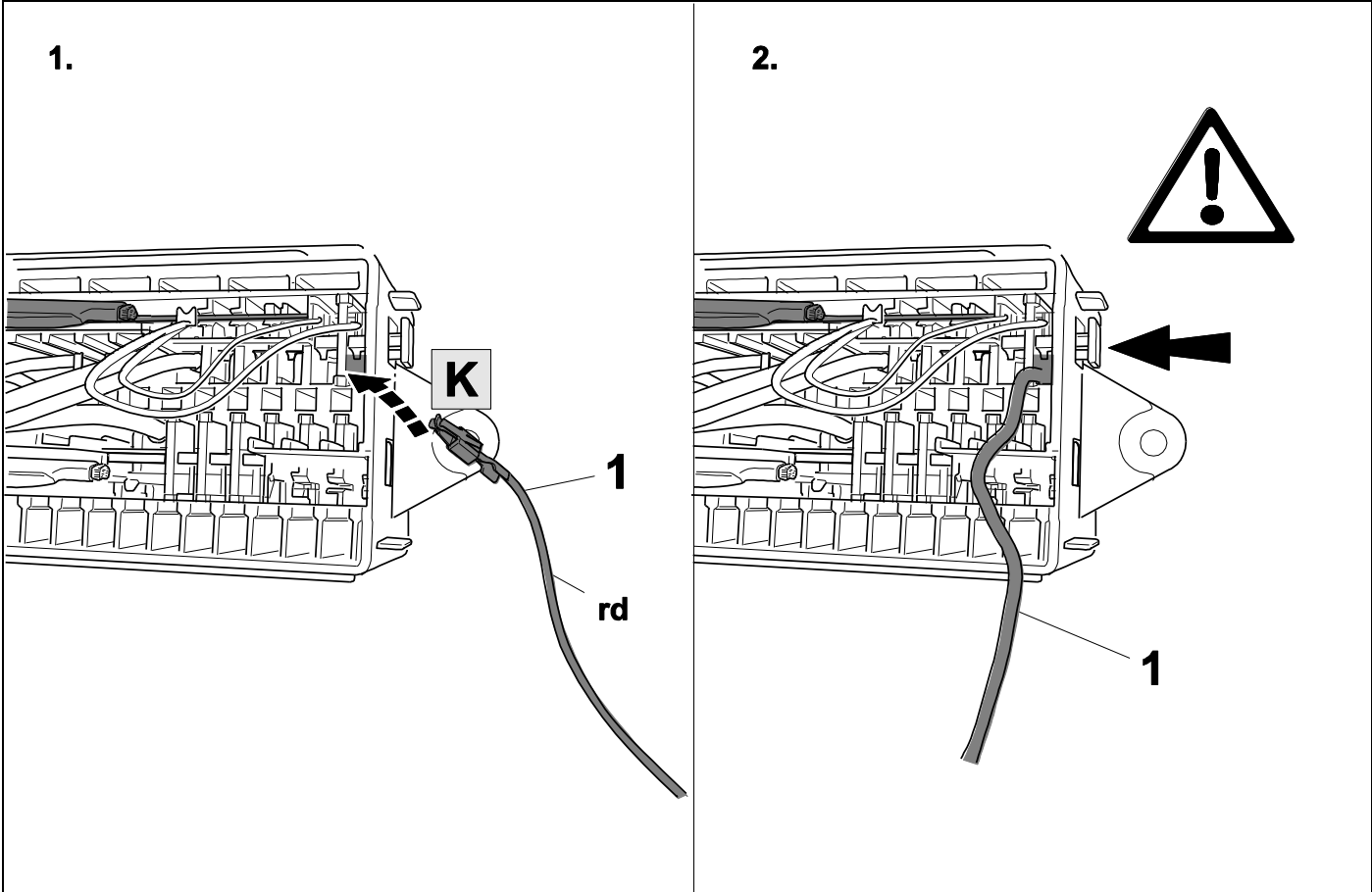

46

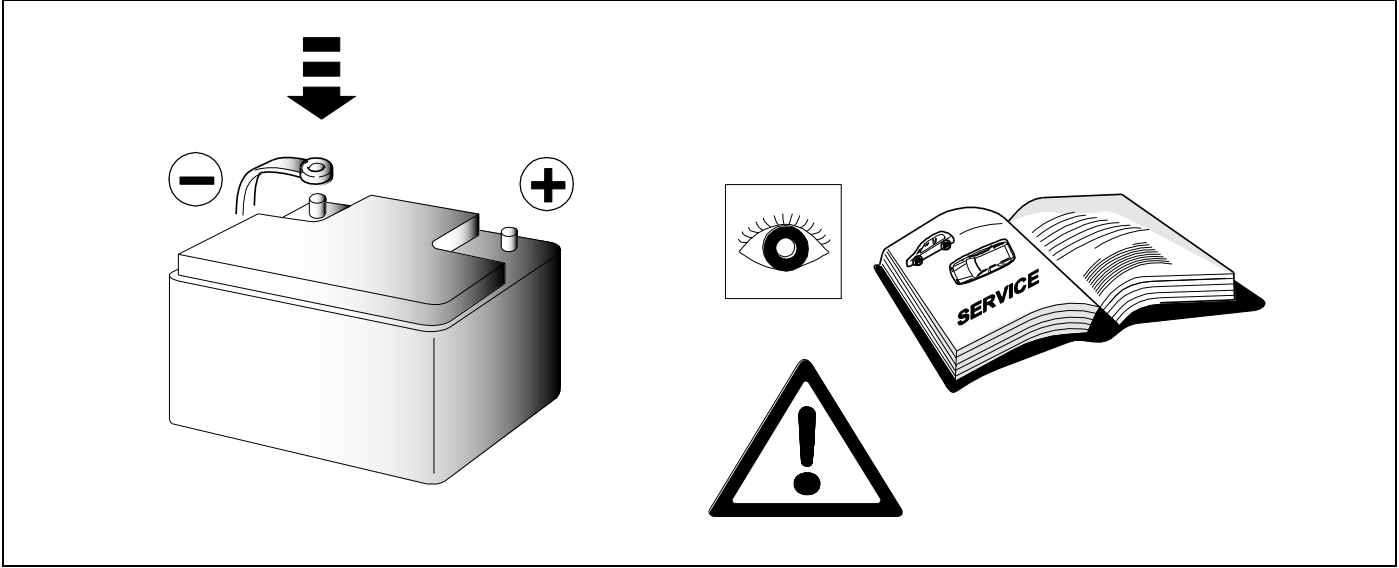

47

CHECK

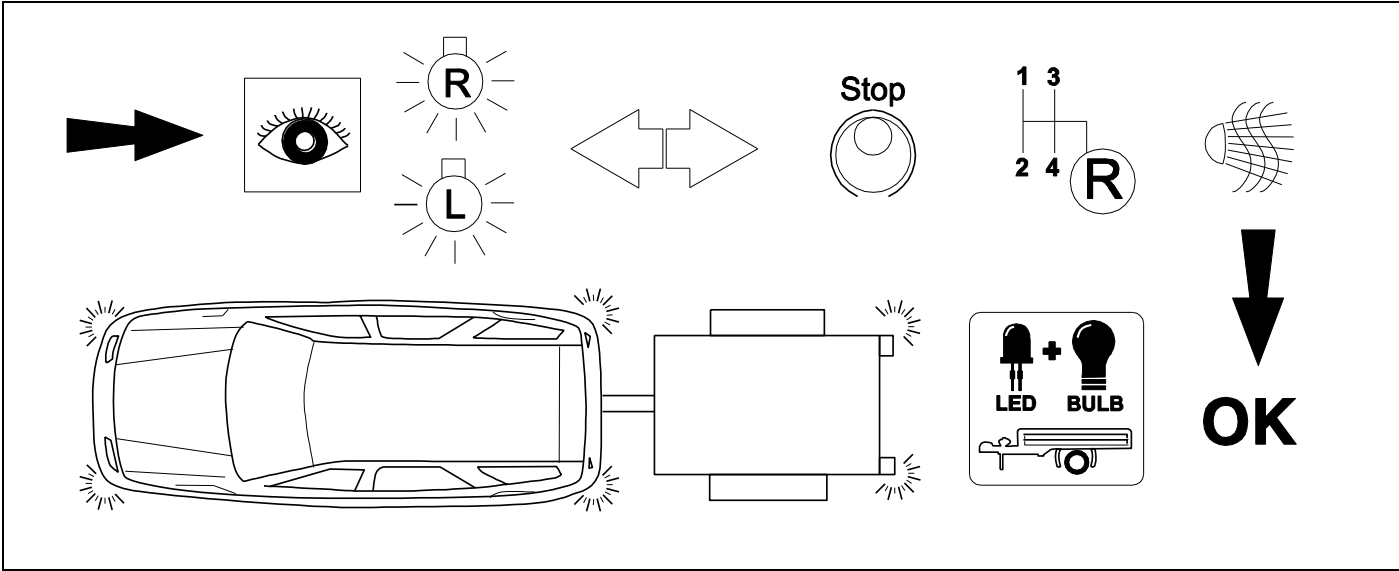

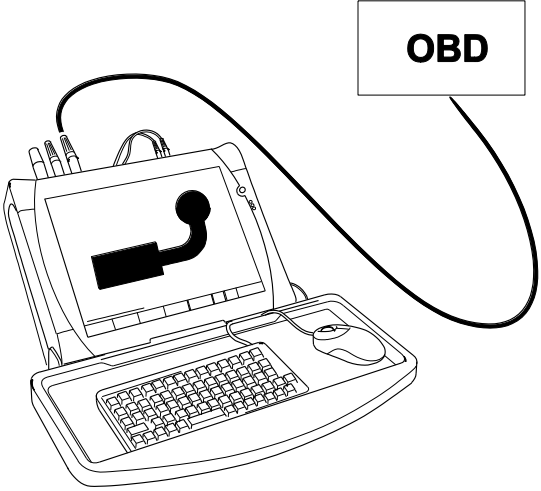

48 CODING



OBD

**Passat Variant
Passat Limousine
Passat CC
Jetta**



49

-

51

D

GB

Codieren des Gatewaysteuergerätes

Das fahrzeugseitige Gateway muss wie nachfolgend beschrieben, unter dem Punkt Eigendiagnose, mit einem VAS-Tester zur Funktionserweiterung Anhängervorrichtung codiert werden:

- Fahrzeug-Eigendiagnose
- Eigendiagnose
- 19 – Diagnoseinterface für Datenbus
- 008-Codierung (Dienst 22)
- 008.02 Verbauliste codieren
- 69 – Anhängerfunktion (auf codiert schalten!)
- mit OK bestätigen!

Fahrzeuge mit Einparkhilfe

Die automatische Deaktivierung der rückwärtigen Einparkhilfe im Anhängerbetrieb wird durch nachfolgende Codierung des Einparkhilfe-Steuergeräts erreicht:

- Fahrzeug-Eigendiagnose
- 10 - Einparkhilfe II
- 009 Codierung
- Master
- 009.02 Klartextcodierung
- Anhängersystem auswählen
- mit OK bestätigen!



Wichtige Hinweise:

Fahrzeuge mit Start-Stopp-Automatik:

➔ Bei Anhängerbetrieb ist die Start-Stopp-Automatik deaktiviert!

Gespannstabilisierung:

Bei den meisten Fahrzeugen ab Modelljahr 2009 kann die automatische Aktivierung der Gespannstabilisierung wie folgt überprüft werden:

- Anhänger elektrisch mit Fahrzeug verbinden
- Nach dem Einschalten der Zündung leuchtet die  Kontrollleuchte zwei Sekunden länger als die  Kontrollleuchte. (siehe auch Fahrzeughandbuch)!

oder Auswertung über Fahrzeugdiagnose:

- Anhänger elektrisch mit Fahrzeug verbinden
- Fahrzeug-Eigendiagnose
- 03 Bremsenelektronik
- 011 Messwerte
- "10" und "Q" eingeben
- Anhänger ja

Encoding the gateway controller

The vehicle gateway must be encoded, as described below, under the point self-diagnostics, by means of a VAS tester for functional expansion of the towing hitch function:

- Vehicle self-diagnosis
- self-diagnosis
- 19 – diagnosis interface for data bus
- 008-Coding (service 22)
- 008.02 assembly list coding
- 69 – trailer function (switch to coded!)
- confirm with OK !

Vehicles with park assist system

The automatic deactivation of the rear park assist system in trailer operation will be effected by means of the subsequent coding of the park assist control unit:

- Vehicle self-diagnosis
- 10 - park assist system II
- 009 Coding
- Master
- 009.02 plain text coding
- select trailer system
- confirm with OK !



NOTE:

Vehicles with start-stop system:

➔ The start-stop system is deactivated in trailer mode!

Towing vehicle and trailer stabilisation:

In most vehicles as of model year 2009 the automatic activation the towing vehicle and trailer stabilisation can be checked as follows:

- Connect trailer to vehicle electrically
- After the ignition has been turned on the control lamp  comes on two seconds longer than control lamp , (see also driver's manual)!

or evaluation via vehicle diagnosis:

- Connect trailer to vehicle electrically
- Vehicle self-diagnosis
- 03 Brake electronics
- 011 Measured values
- Enter "10" and "Q"
- Trailer yes

F

Codage du calculateur Gateway

Coder comme suit le Gateway du véhicule selon la description suivante, point diagnostic final, avec un contrôleur VAS pour l'extension du dispositif d'attelage :

- autodiagnostic du véhicule
- autodiagnostic
- 19 – interface de diagnostic pour
- bus de données
- 008-codage (service22)
- 008.02-codage liste d'assemblage
- 69 – mode remorque (commuter à encodé!)
- Confirmer en appuyant sur OK

Veicoli con sensori di parcheggio

L'aide au parking arrière est désactivée automatiquement dans le mode remorque par le codage suivant du dispositif de commande du système d'aide au parking:

- autodiagnostic du véhicule
- 10 - système d'aide au parking II
- 009 Codage
- Master
- 009.02 Codage en langage clair
- Sélectionner le système remorque
- Confirmer en appuyant sur OK



AVERTISSEMENT:

Véhicules avec système automatique de démarrage et d'arrêt :

➔ **Le système automatique de démarrage et d'arrêt est désactivé pendant le remorquage.**

Stabilisation de l'attelage :

L'activation automatique de la stabilisation de l'attelage peut être vérifiée sur la plupart des véhicules construits à partir de 2009 de la manière suivante :

- Relier le système électrique de la remorque à celui du véhicule Une fois l'allumage en marche, le voyant  reste allumé deux secondes plus longtemps que le voyant  (cf. aussi le manuel du véhicule)!

ou l'évaluation réalisée via le système de diagnostic du véhicule comme suit :

- Relier le système électrique de la remorque à celui du véhicule
- Auto-diagnostic du véhicule
- 03 Système électronique de freinage
- 011 Valeurs mesurées
- Entrer «10» et «Q»
- Remorque «Oui»

I

Codifica della centralina gateway

Il gateway della vettura, per l'espansione delle funzioni al gancio traino, deve essere codificato con un tester VAS nell'autodiagnosi, nel modo descritto qui di seguito:

- Autodiagnosi del veicolo
- Autodiagnosi
- 19 – Interfaccia di diagnosi per il data bus
- 008-codifica (servizio 22)
- 008.02-codifica Lista
- 69 – Funzione rimorchio (commutare su codificato!)
- Confermare con OK!

Veicoli con sensori di parcheggio:

La disattivazione automatica dei sensori di parcheggio posteriori quando è attaccato un rimorchio si ottiene attraverso la seguente programmazione della centralina di controllo dei sensori:

- Autodiagnosi del veicolo
- 10 - sensori di parcheggio II
- 009 Codifica
- Padrone
- 009.02 codifica testo
- selezionare sistema rimorchio
- Confermare con OK!



AVVERTENZA:

Veicoli con start-stop automatico:

➔ **Nel funzionamento con rimorchio lo start-stop automatico è disattivato!**







Sistema di stabilizzazione rimorchio:

nella maggior parte dei veicoli a partire dall'anno modello 2009 si può verificare l'attivazione automatica del sistema di stabilizzazione rimorchio come segue:

- collegare il rimorchio elettricamente con il veicolo
- all'inserimento dell'accensione si accende la spia di controllo  due secondi di più rispetto alla spia di controllo  (vedi anche manuale del veicolo)!

oppure elaborazione tramite il sistema di diagnosi dell'automezzo:

- collegare il rimorchio elettricamente con il veicolo
- autodiagnosi del veicolo
- 03 elettronica dei freni
- 011 valori di misura
- digitare "10" e "Q"
- rimorchio sì

<div style="text-align: center;">  </div>	<div style="text-align: center;">  </div>
<p>Coderen van het gateway besturingsapparaat</p> <p>De gateway aan voertuigzijde moet zoals hierna beschreven onder punt Eigendiagnose, met een VAS-tester voor de functie-uitbreiding aanhangwageninrichting</p> <p>Gelieve codering als volgt door te voeren:</p> <ul style="list-style-type: none"> • Eigendiagnose voertuig • Eigendiagnose • 19 – diagnose-interface für gegenvensinvoerbus • 008-Codering (dienst 22) • 008.02-Codering inbouwljst • 69 – aanhangwagenfunctie (op “Gecodeerd” schakelen!) <p>Voertuigen met parkeerhulp:</p> <p>Bij voertuigen met parkeerhulp dient de regeleenheid van de parkeerhulp als volgt te worden gecodeerd:</p> <ul style="list-style-type: none"> • Eigen diagnose voertuig • 10 - parkeerhulp II • 009 Codering • Meester • 009.02 Codering tekst • Selecteer aanhangwagen • met OK bevestigen! <p>AANWIJZING:</p> <p>Voertuigen met automatische start/stop:</p> <p>➔ In de modus “Aanhangwagen” is de automatische start/stop gedeactiveerd!</p> <p>Stabilisatie van de auto met aanhangwagen:</p> <p>Bij de meeste voertuigen vanaf modeljaar 2009 kan de automatische activering van de stabilisatie van de auto met aanhangwagen als volgt gecontroleerd worden:</p> <ul style="list-style-type: none"> • Aanhangwagen elektrisch met voertuig verbinden • Na het inschakelen van de ontsteking is het controlelampje  twee seconden langer dan het controlelampje  verlicht, (zie ook voertuighandboek!) <p>of analyse van de voertuigdiagnose:</p> <ul style="list-style-type: none"> • Aanhangwagen elektrisch met voertuig verbinden • Eigen diagnose van het voertuig • 03 remelektronica • 011 meetwaarden • "10" en "Q" invoeren • Aanhangwagen ja 	<p>Codificación de la unidad de control del Gateway</p> <p>El Gateway del vehículo debe codificarse con un analizador VAS para ampliar las funciones del dispositivo de remolque en el autodiagnóstico, como se describe seguidamente:</p> <p>Codificar del siguiente modo:</p> <ul style="list-style-type: none"> • Autodiagnóstico del vehículo • Autodiagnóstico • 19 - Interfaz de diagnóstico para bus de datos • 008-Codificación (servicio 22) • 008.02-Codificación Lista • 69 - Función del remolque (codificación) <p>Vehiculos con sistema de ayuda para el aparcamiento:</p> <p>En vehículos con sistema de ayuda para el aparcamiento (PDC) se debe codificar la unidad de control PDC del siguiente modo:</p> <ul style="list-style-type: none"> • Autodiagnóstico vehículo • 10 - ayuda al aparcamiento II • 009 Codificación • Maestro • 009.02 Codificación de texto • Remolque seleccione • ¡Confirmar con OK! <p>NOTA:</p> <p>Vehículos con sistema automático de arranque y parada:</p> <p>➔ ¡En el servicio con remolque, el sistema automático de arranque y parada está desactivado!</p> <p>Estabilización del tiro:</p> <p>En la mayoría de los vehículos a partir del año de fabricación 2009 podrá comprobarse la activación automática de estabilización del tiro de la siguiente manera:</p> <p>Establecer una conexión eléctrica entre el remolque y el vehículo Después de encender el contacto, la lámpara piloto  se ilumina durante dos segundos más que la lámpara piloto , ¡véase también el manual del vehículo!)</p> <p>o evaluación por medio del diagnóstico del vehículo:</p> <ul style="list-style-type: none"> • Establecer una conexión eléctrica entre el remolque y el vehículo • Autodiagnóstico del vehículo • 03 Sistema electrónico de frenos • 011 Valores medidos • Introducir "10" y "Q" • Remolque sí

52 OPTIONAL

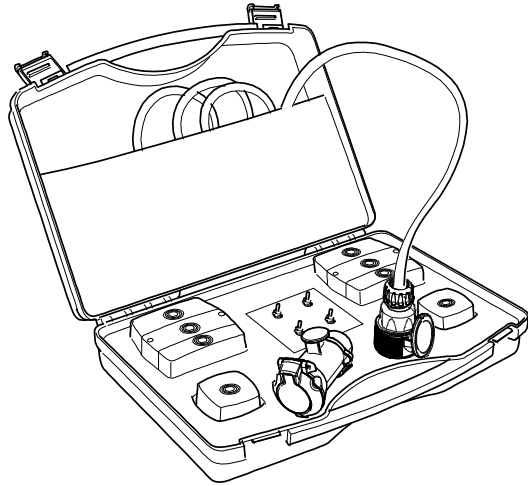

**Trailer Simulator
for 7p and 13p
sockets**

765069

53 CHECK

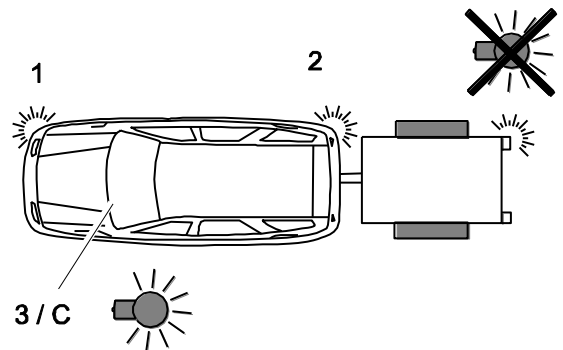
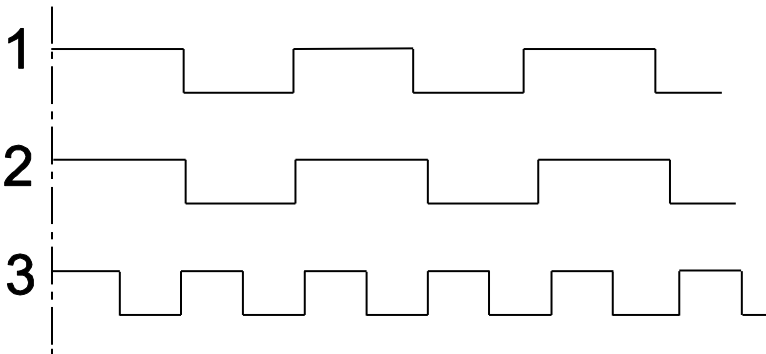

54 CHECK OPTION ORIGINAL PDC

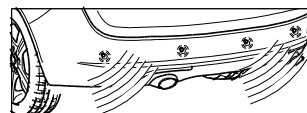
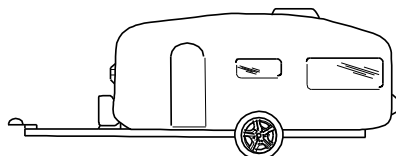
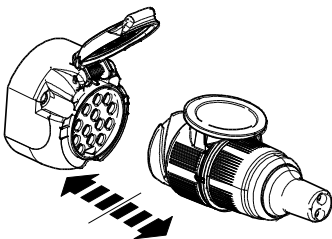
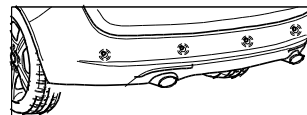
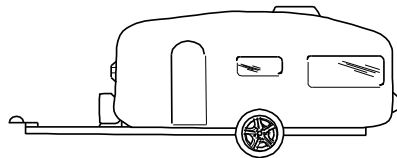
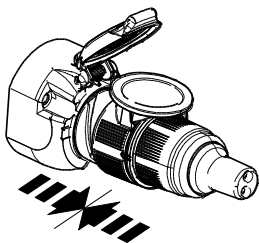

55 Information Service  ⇒ **37** + **42** + **45**

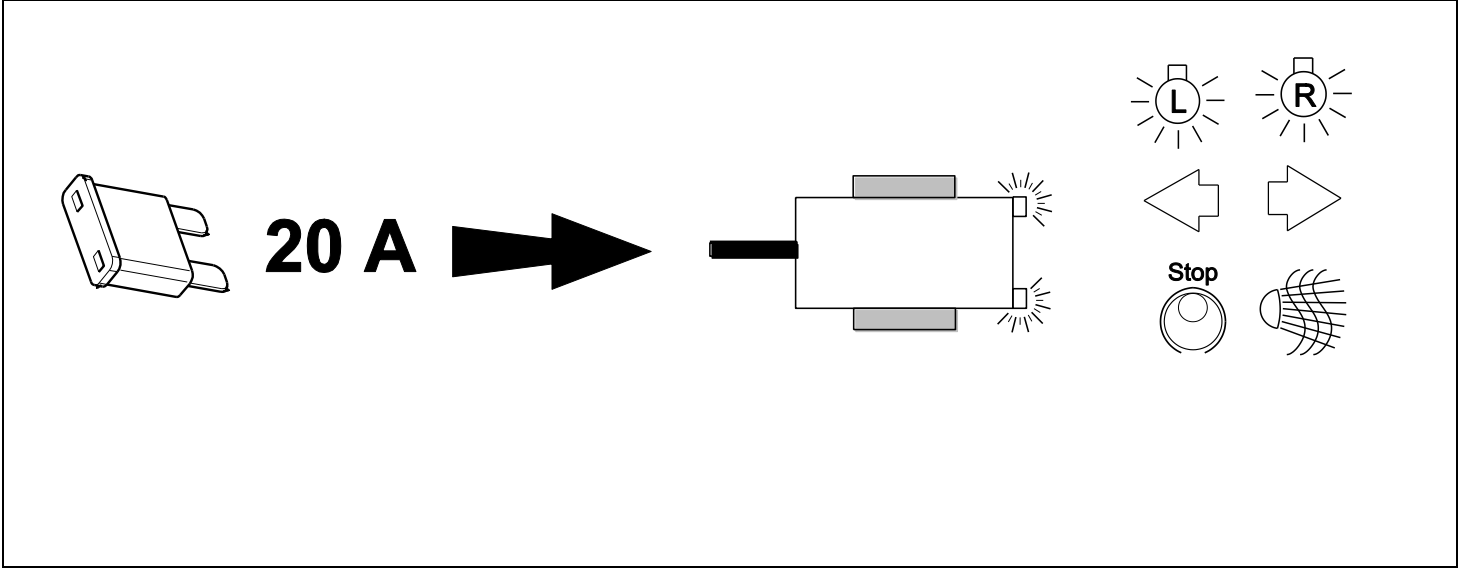

56 OPTIONAL  ⇒ **BRiNK**

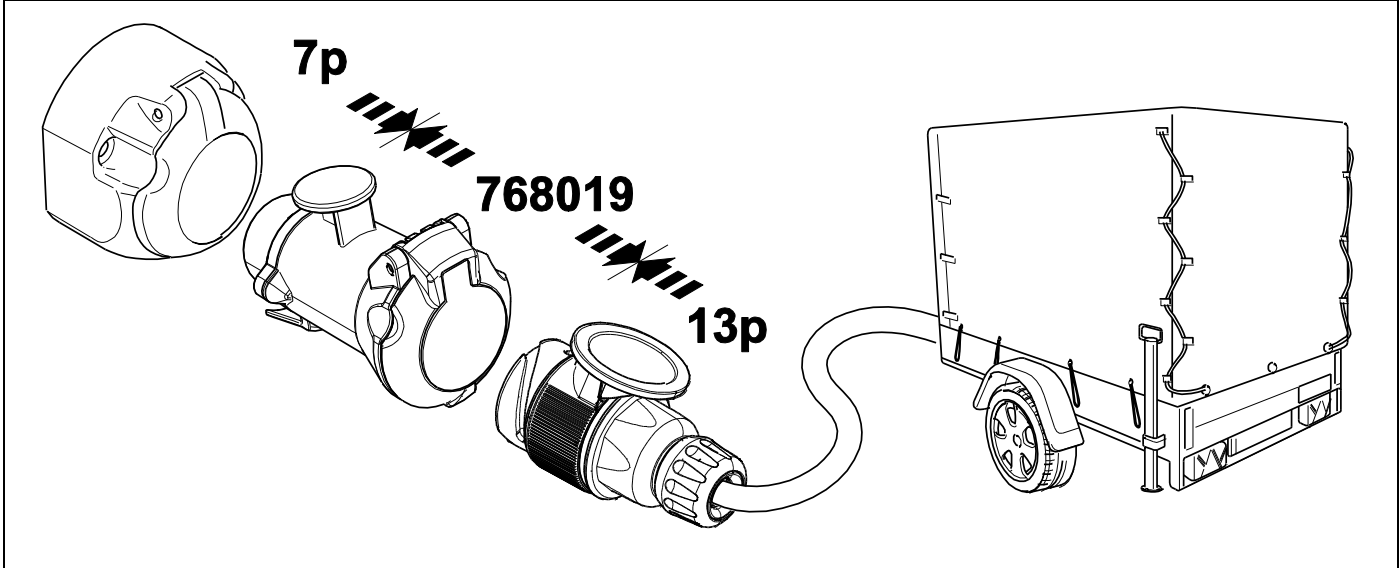

57 PLEASE NOTICE

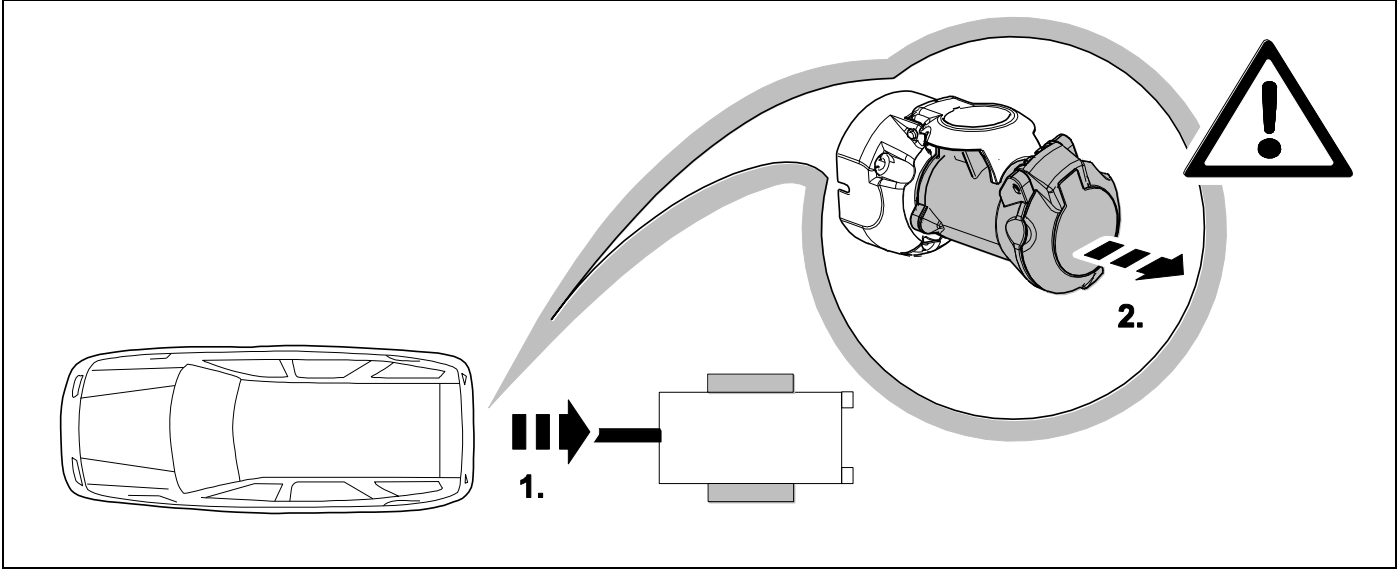



Need help programming this wiringkit? Use Jifeline to program this wiringkit

*Please check the voucher added to this wiringkit and
learn how to program this wiringkit with Jifeline.*



2x 13

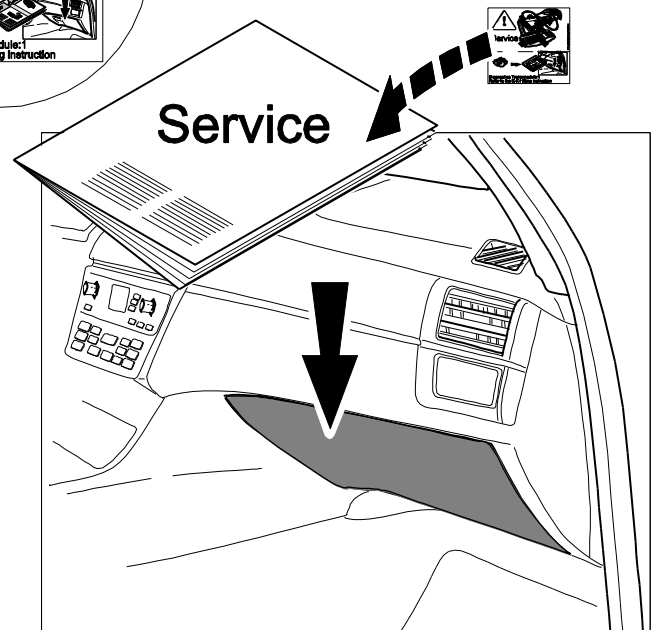
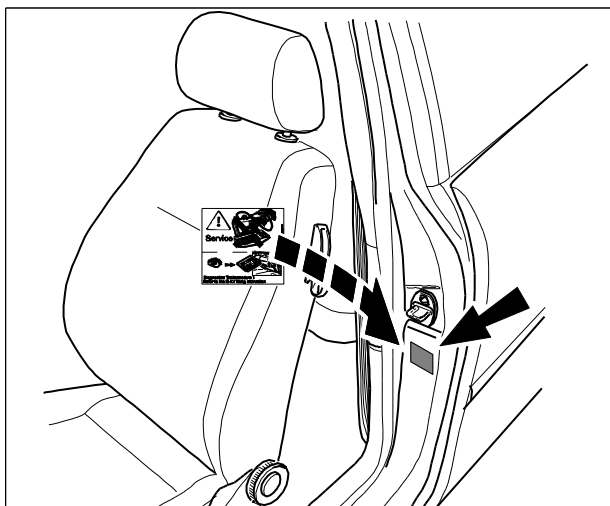
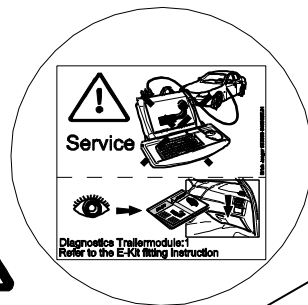

Status LED für Eigendiagnose

Status LED for self-diagnosis

Operation support

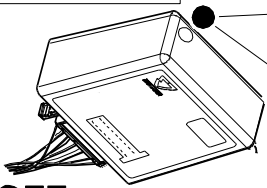
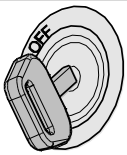

No CAN-Data =



Standby / Sleepmode



Ignition OFF

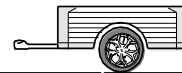
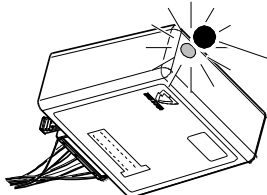

Ignition ON

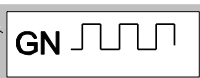
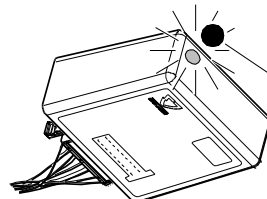

Ignition ON

Failure support

CAN-Data Wire



1x max. 5 min.

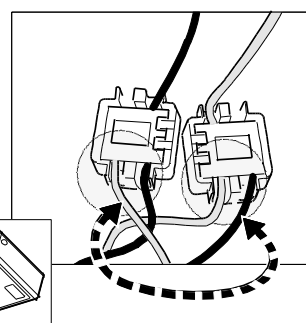
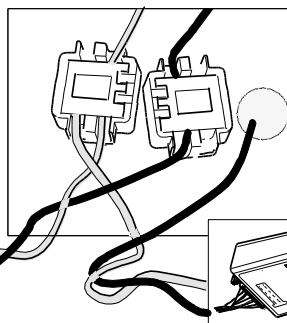
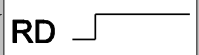
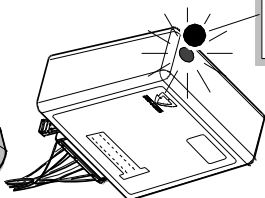

Ignition ON

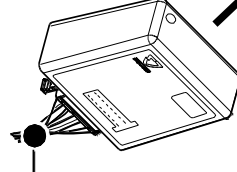
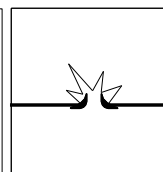
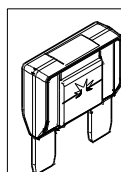
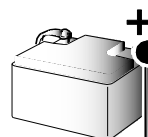
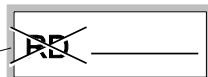
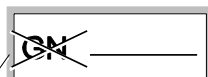
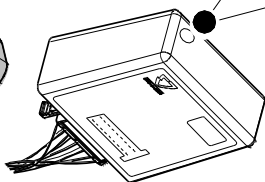
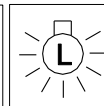
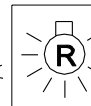

Ignition ON



PIN 17 oder / or



PIN 1



<p>D Änderungen bezüglich Konstruktion, Ausstattung Farbe sowie Irrtum vorbehalten. Angaben und Abbildungen unverbindlich</p>	<p>PL Zastrzega się prawo do zmian dot. konstrukcji, wykończenia, kolorystyki oraz pomyłek. Dane i ilustracje niewiążące.</p>
<p>GB Subject to change in terms of construction, equipment and colour, and may contain errors. The information and illustrations are non-binding.</p>	<p>TR Tasarım, donanım ve renk bakımından değişiklik yapma hakkı ve hata ve eksiklik mahfuzdur. Veriler ve resimler bağlayıcı değildir.</p>
<p>F Sous réserve de modifications de la construction, de l'équipement, de la couleur et sous réserve d'erreurs. Les indications et les illustrations sont sans engagement.</p>	<p>H A szerkezet, a kivitelt és a szín változtatása, valamint a változások joga fenntartva. Az adatok és az ábrák nem kötelező érvényűek.</p>
<p>NL Wijzigingen met betrekking tot constructie, uitvoering en kleur evenals vergissingen voorbehouden. Gegevens en afbeeldingen niet bindend.</p>	<p>HR Pravo promjena u svezi konstrukcije, opreme, boje kao i zabune oridžavamo. Podaci i ilustracije su neobavezne.</p>
<p>DK Ændringer med hensyn til konstruktion, udstyr, farver samt fejl forbeholdes. Oplysninger og illustrationer er uforpligtende.</p>	<p>BUL Запазени права по отношение на конструкцията, обзавеждането, цвета и грешки. Данните и изображенията не са обвързващи.</p>
<p>N Endringer angående konstruksjon, utstyr, farge og feiltagelse forbeholdes. Oplysninger og illustrasjoner uforbindtlig.</p>	<p>RO Ne rezervăm dreptul unor modificări ale construcției, dotării, culorii și dreptul la erori Datele indicate și imaginile sunt orientative.</p>
<p>S Med reservation för ändringar vad det gäller konstruktion, utrustning, färg samt för misstag. Uppgifterna och bilderna är inte bindande.</p>	<p>RU Права на внесение изменений относительно конструкции, оснащения, окраски, а также на ошибки сохраняются. Данные и иллюстрации имеют примерный характер.</p>
<p>FIN Pidätämme oikeuden rakennetta, varustusta, väriä koskeviin sekä erehdyksestä johtuviin muutoksiin. Tiedot ja kuvat eivät ole sitovia.</p>	<p>LT Pasiliekaama konstrukcijos, įrangos bei reikmenų, spalvos pakeitimų ir klaidų teisė. Duomenys ir iliustracijos neįpareigojantys.</p>
<p>I Con riserva di modifiche relative a progettazione, dotazione, colore ed errori. Le indicazioni e figure sono fornite senza impegno.</p>	<p>LV Tiek paturētas tiesības uz konstrukcijas, iekārtu, krāsu izmaiņām, kā arī kļūdīšanās. Dati un attēli bez saistībām.</p>
<p>E Reservadas las modificaciones respecto a diseño, equipamiento, color, así como error. Indicaciones y figuras sin compromiso.</p>	<p>EST Konstruktsiooni, varustuse ja võevi osas muudatused ning eksimine lubatud. Andmed ja joonised on mittesiduvad.</p>
<p>P Reservamos o direito de alterações relativamente ao desenho, equipamento, cor, bem como de erro. Os dados e as gravuras não implicam compromisso da nossa parte.</p>	<p>SLO Zadržana pravica do sprememb glede konstrukcije, opreme, barve ter pomote. Podatki in slike so neobvezne.</p>
<p>GR Διατηρώνουμε κάθε επιφύλαξη ως προς αλλαγές σε σχέση με κατασκευή, εξοπλισμό, διαρρύθμιση, χρωματισμούς και λάθη παραδρομής.</p>	<p>SK Zmeny, ktoré sa týkajú konštrukcie, vybavenia, farby, ako aj omyly sú vyhradené. Údaje a zobrazenia sú nezáväzné.</p>
<p>CZ Změny, týkající se konstrukce, vybavení, barvy, jakož i omyly jsou vyhrazeny. Údaje a vyobrazení jsou nezávazné.</p>	